

PAN™ 19

MECHANICAL SLIDING CALLIPER DISC BRAKE

REPAIR AND MAINTENANCE INSTRUCTIONS



WABCO

Mobilizing Vehicle Intelligence

Original document:

The German version is the original document.

Translation of the original document:

All non-German language editions are translations of the original document.

Edition 4, Version 2 (11.2019)

Document no.: 815 010 063 3 (en)



You will find the current edition at:

<http://www.wabco.info/i/1347>

Table of contents

1	Symbols used	5
2	Safety information	6
3	Information about this document	7
3.1	Target group for this document	7
3.2	Validity of this document	7
4	Description of the disc brake	8
4.1	Introduction	8
4.2	Views of the disc brake	9
4.3	Functional description	10
4.4	Exploded view of the replacement parts	11
5	Tools, spanner widths and tightening torques	12
6	WABCO tools	13
7	Checking the brake	14
7.1	Checking adjuster function	14
7.2	Checking the brake linings	16
7.2.1	Visual check of the brake linings	16
7.2.2	Measuring the brake lining wear	16
7.2.3	Measuring the thickness of the brake linings	18
7.3	Checking the brake discs	19
7.3.1	Visual check of the brake discs	20
7.3.2	Checking the brake disc run-out	20
7.4	Checking the bearing play of the guide pins	21
8	Replacing the brake linings	23
8.1	Preparatory activities	23
8.2	Resetting	24
8.3	Removing the brake linings	25
8.4	Checking the movement of the calliper	27
8.5	Checking the protective pin caps	27
8.6	Installing the pressure plate	28
8.7	Installing the brake linings	29
8.8	Adjusting the clearance	29
8.9	Laying the sensor cable	30
9	Replacing the brake cylinder	33
9.1	Removing the brake cylinder	33
9.2	Installing the brake cylinder	34
10	Replacing the brake	36
10.1	Removing the brake	36
10.2	Installing the brake	37

Table of contents

11 Replacing the seals	39
11.1 Replacing the closure caps and the bushings of the guide pins	39
11.1.1 Disassembling the bushings	39
11.1.2 Mounting the bushings	41
11.2 Replacing the protective pin caps	42
11.3 Replacing the plunger cap	46
11.3.1 Removing the plunger cap	46
11.3.2 Installing the plunger cap	48
11.4 Replacing the return unit seal	51
11.4.1 Removing the return unit seal	51
11.4.2 Installing the return unit seal	52
12 Final activities	54
13 Spare parts	55
14 Disposal	56
15 WABCO regional offices	57

1 Symbols used

DANGER

The signal word denotes a hazard with a high degree of risk which, if not avoided, will result in death or serious injury.

WARNING

The signal word denotes a hazard with a medium degree of risk which, if not avoided, can result in death or serious injury.

CAUTION

The signal word denotes a hazard with a low degree of risk which, if not avoided, may result in minor or moderate injury.

NOTICE

The signal word denotes a hazard which, if not avoided, can result in material damage.



Important information, notes and/or tips



Reference to information on the internet

Descriptive text

– Action step

1. Action step 1 (in ascending order)

2. Action step 2 (in ascending order)

⇒ Consequence of an action

■ Listing

• Listing

 **Note on the use of a tool / WABCO tool**

2 Safety information

Requirements and protective measures

- Follow all warning notes, notices and instructions in this document to avoid personal injury and material damage.
- Follow the company's accident prevention regulations as well as regional and national regulations.
- Follow the instructions of the axle and vehicle manufacturer.
- Observe the instructions of the brake cylinder manufacturer.
- Use protective equipment if required (safety footwear, protective eyewear, respiratory protection, ear defenders, etc.).
- Only trained and qualified technicians may carry out work on the vehicle.
- The workplace has to be dry, as well as sufficiently lit and ventilated.
- Before performing any work on the brake, secure the vehicle against rolling away with wheel chocks.
- Before carrying out any work on the brake, actuate the release mechanism if Tristop cylinders are installed.
- A second person must assist with the removal and installation of the brake.

Proper working practice

- Use suitable equipment, such as a vice, to clamp the brake when performing repairs on the brake outside the vehicle.
- Check the brake lining thickness at regular intervals in relation to the vehicle use, during maintenance intervals, as well as in the context of applicable local laws and regulations.
- Only hold the outside of the calliper.
- Only use spare parts approved by WABCO or the vehicle manufacturer.
- Only use grease contained in the repair kits.
- Only use brake cylinders as specified by the axle or vehicle manufacturer.
- Perform the repair work using only the recommended tools and tightening torques.

Improper activities

- Do not use compressed air or other high-pressure devices when cleaning the brake or the vehicle. Hazardous dusts arising may lead to injuries. Rubber parts of the brake could also be damaged.
- Do not use motor-powered screwdriver or torque tools.
- Never open the calliper using the clamping unit.
- Never loosen the fastening screws on the cover of the calliper.

3 Information about this document

3.1 Target group for this document

This document is intended for use by trained and qualified technicians.

3.2 Validity of this document

This document applies to the following WABCO part numbers:

640 195 XXX 0

40 195 XXX

This document lists all the components of a PAN19 disc brake and the associated steps so that all PAN19 variants can be serviced and repaired with the aid of this document.

4 Description of the disc brake

4.1 Introduction

The PAN19 disc brake is a pneumatic single-piston brake, which is intended for use on commercial vehicles on front and rear axles for 19.5" and 22.5" rims as a service, auxiliary and parking brake.

The PAN19 disc brake is actuated mechanically via a diaphragm brake cylinder or a spring brake actuator. The brake cylinder is attached directly to the calliper (1).

The complete PAN19 disc brake, including the brake cylinder, comprises two assemblies: Calliper (1) and brake carrier (2).

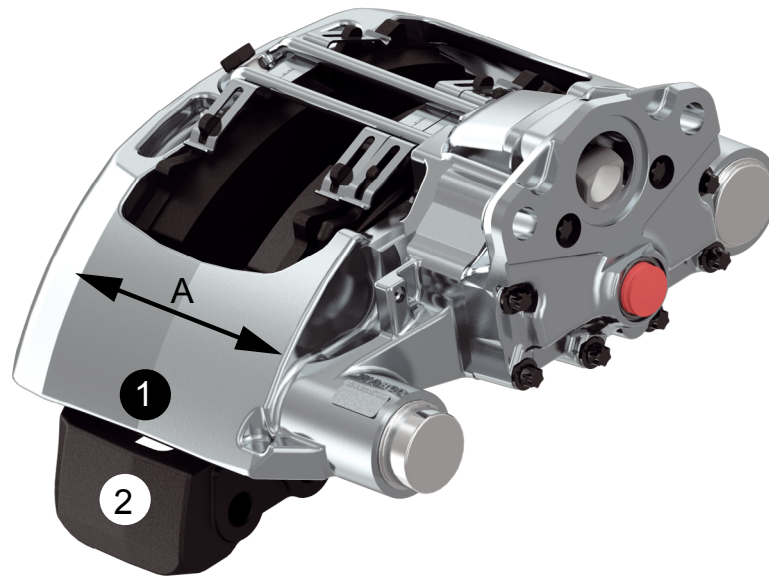

Legend	
1	Calliper
2	Brake carrier
A	Calliper shifting direction

Description of the disc brake

4.2 Views of the disc brake

Top view and sectional view (left brake)

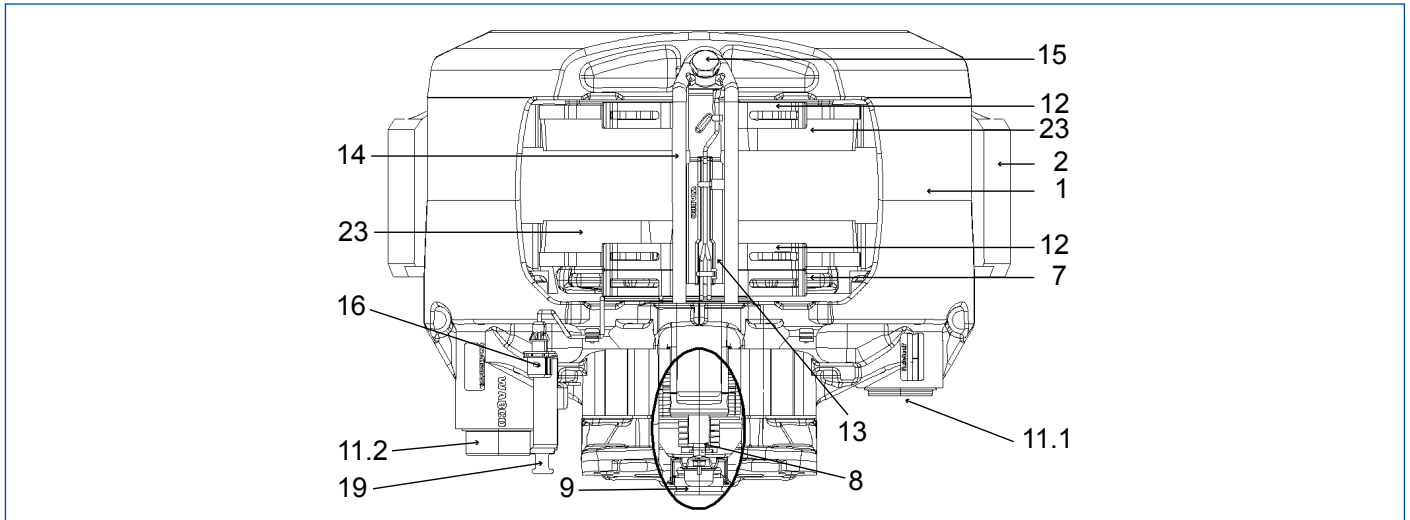

Side view and sectional view (left brake)

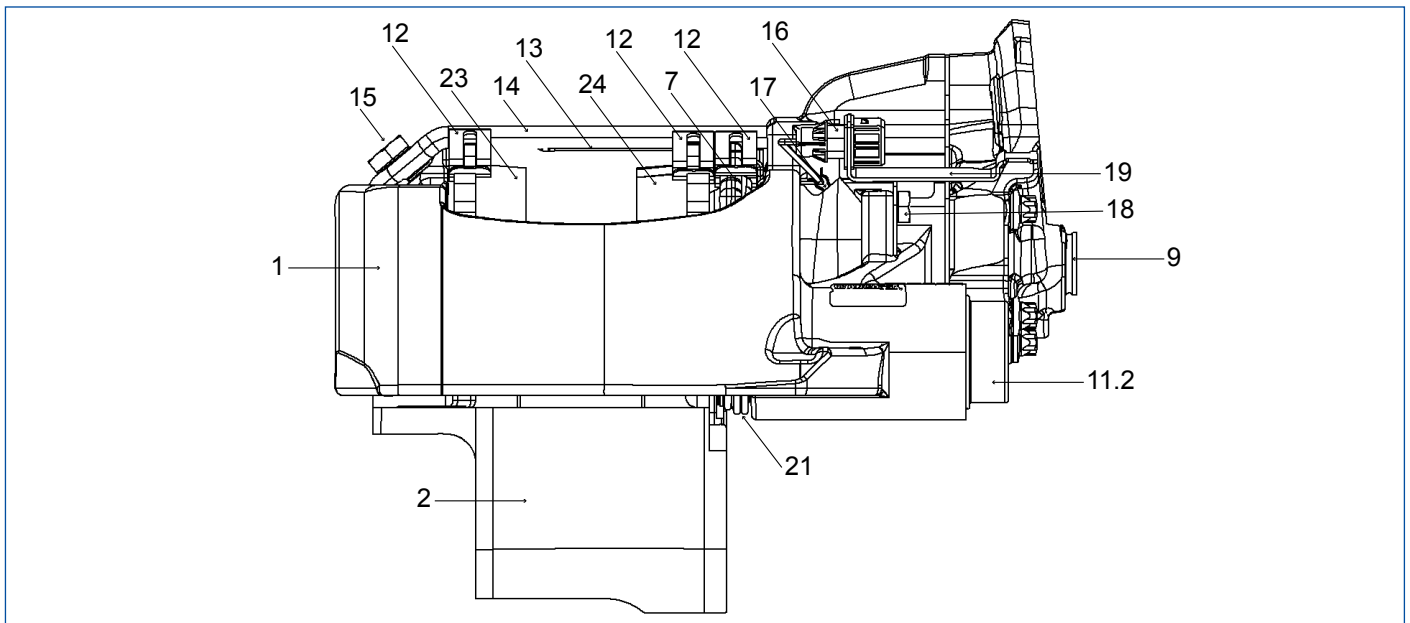

Legend

1	Pre-assembled calliper with clamping unit	11.2	Closure cap (long)	17	Cable clip, 2x
2	Brake carrier	12	Hold-down springs	18	Screw for connector retaining plate
7	Pressure plate	13	Cable guide plate	19	Connector retaining plate
8	Return unit hexagon	14	Lining retainer clip	21	Protective pin caps, 2x
9	Return unit sealing plug	15	Hexagon screw	23	Brake lining on rim side with pre-assembled hold-down spring
11.1	Closure cap (short)	16	Wear indicator	24	Brake lining on cylinder side with pre-assembled hold-down spring

Description of the disc brake

Bottom view and sectional view (left brake)

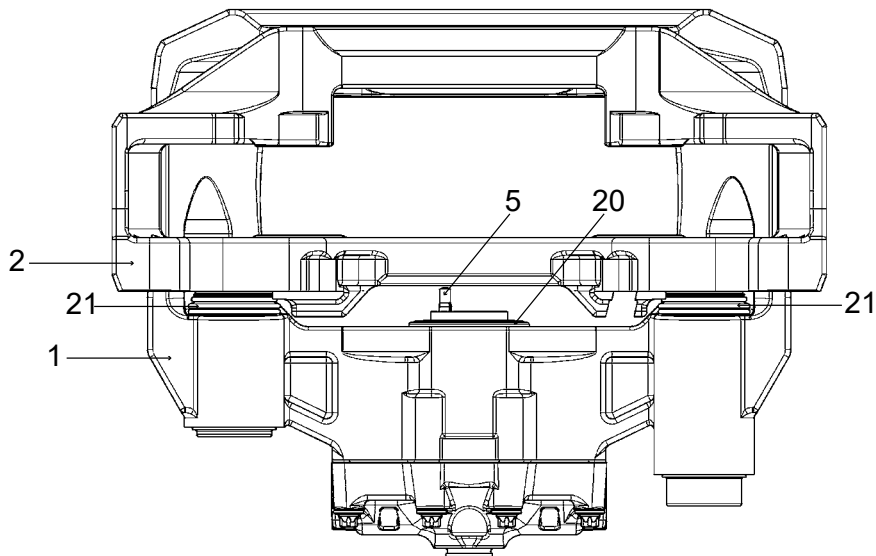

Legend

1	Pre-assembled calliper with clamping unit	5	Adjusting screw	21	Protective pin caps, 2x
2	Brake carrier	20	Plunger cap		

4.3 Functional description

The calliper (1) moves axially on guide pins (3, 4) of the brake carrier (2). The brake linings (23, 24) are guided and supported axially movable in the brake carrier (2). The brake lining support (23, 24) is implemented by means of a lining retainer clip (14) and hold-down springs (12).

For compensating the lining wear the actuating mechanism of the brake is equipped with a force-dependent, continuous automatic adjuster mechanism. This mechanism maintains a preset clearance regardless of load and operating conditions. This, together with the stable and robust construction of the calliper (1), results in safe control of the pedal travel and increases the reserve of travel for emergency braking.

All rubber parts and the grease fillings are maintenance-free except when damaged.

The disc brake is optionally equipped with an electrical wear indicator (16) (threshold indicator).

When the indicator in the vehicle lights up, the residual lining thickness has been reached. Worn brake linings (23, 24) have to be replaced at a workshop.

Description of the disc brake

4.4 Exploded view of the replacement parts



WABCO repair kits and service documents

<http://inform.wabco-auto.com>

Illustration of replacement parts (example of a left brake)

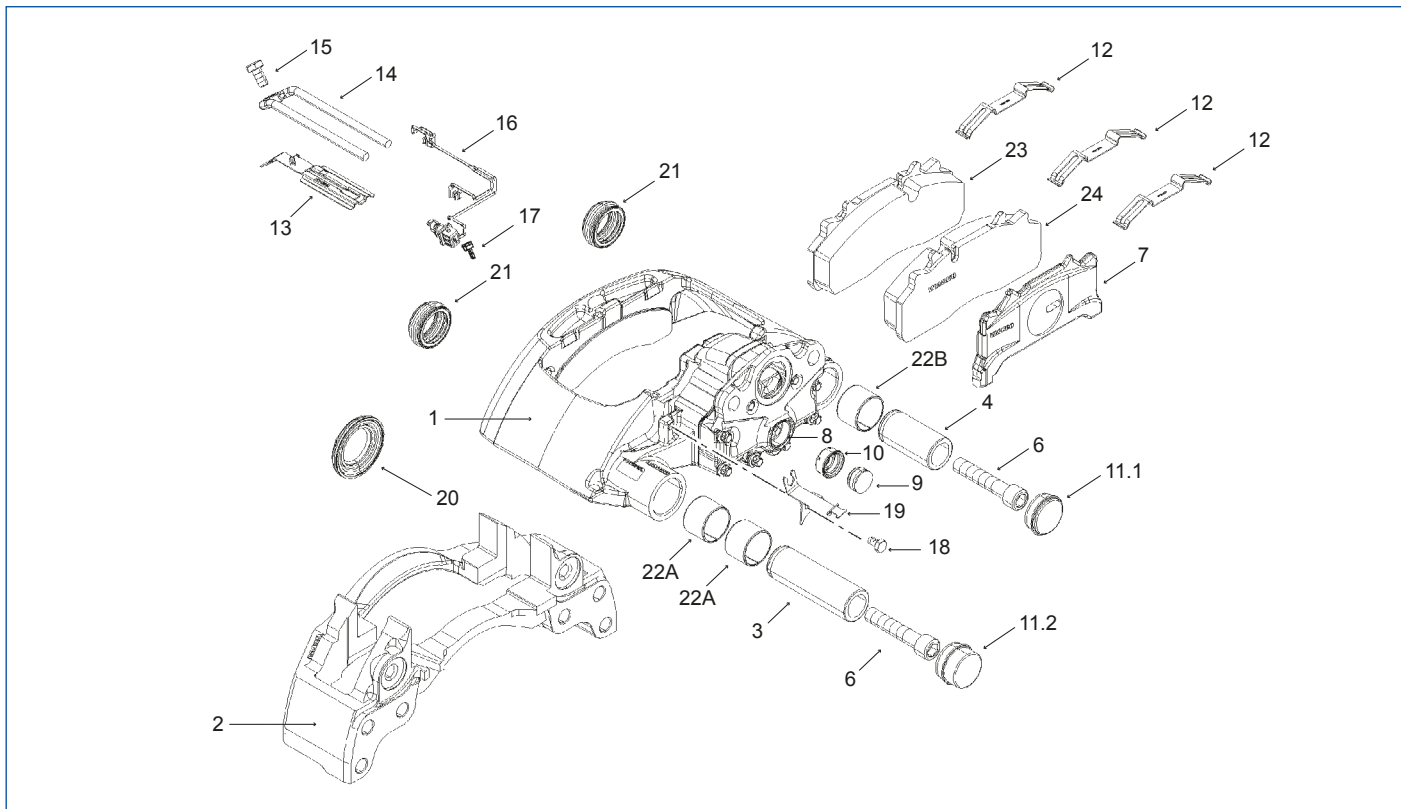

Legend

1	Pre-assembled calliper with clamping unit	10	Return unit seal	17	Cable clip, 2x
2	Brake carrier	11.1	Closure cap (short)	18	Screw for connector retaining plate
3	Guide pins, long (fitting pins)	11.2	Closure cap (long)	19	Connector retaining plate
4	Guide pins, short (clearance bolts)	12	Hold-down springs	20	Plunger cap
6	Hexagon socket screw, 2x	13	Cable guide plate	21	Protective pin caps, 2x
7	Pressure plate	14	Lining retainer clip	22	22A Bushings on the long guide pin, 2x 22B Bushing on the short guide pin, 1x
8	Return unit hexagon	15	Hexagon screw	23	Brake lining on rim side with pre-assembled hold-down spring
9	Return unit sealing plug	16	Wear indicator	24	Brake lining on cylinder side with pre-assembled hold-down spring

5 Tools, spanner widths and tightening torques

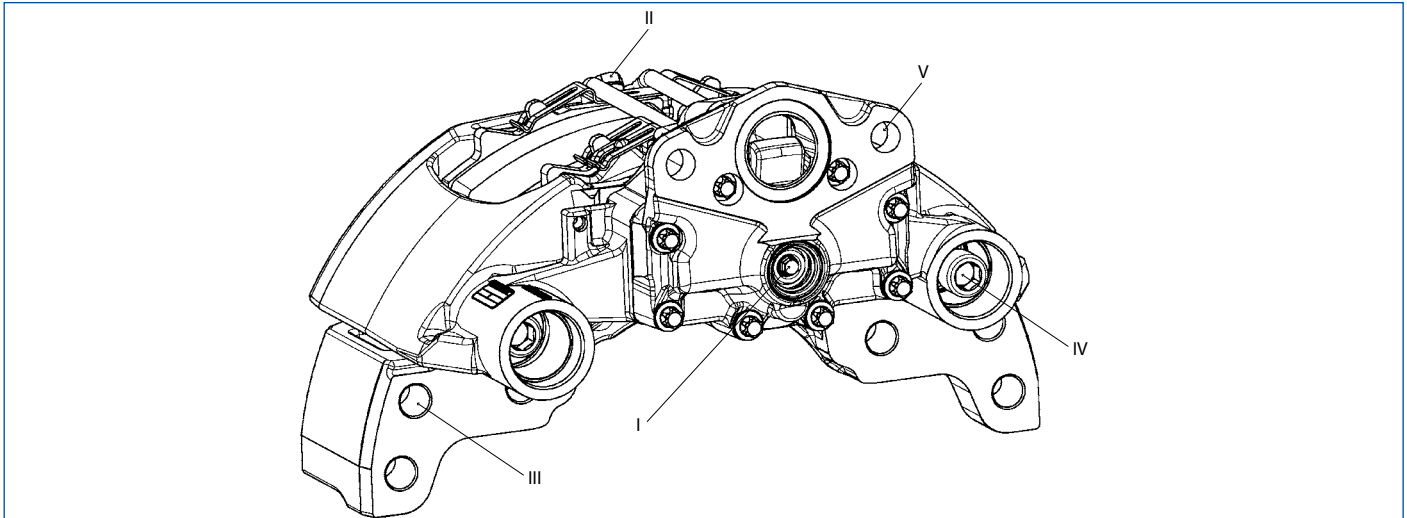



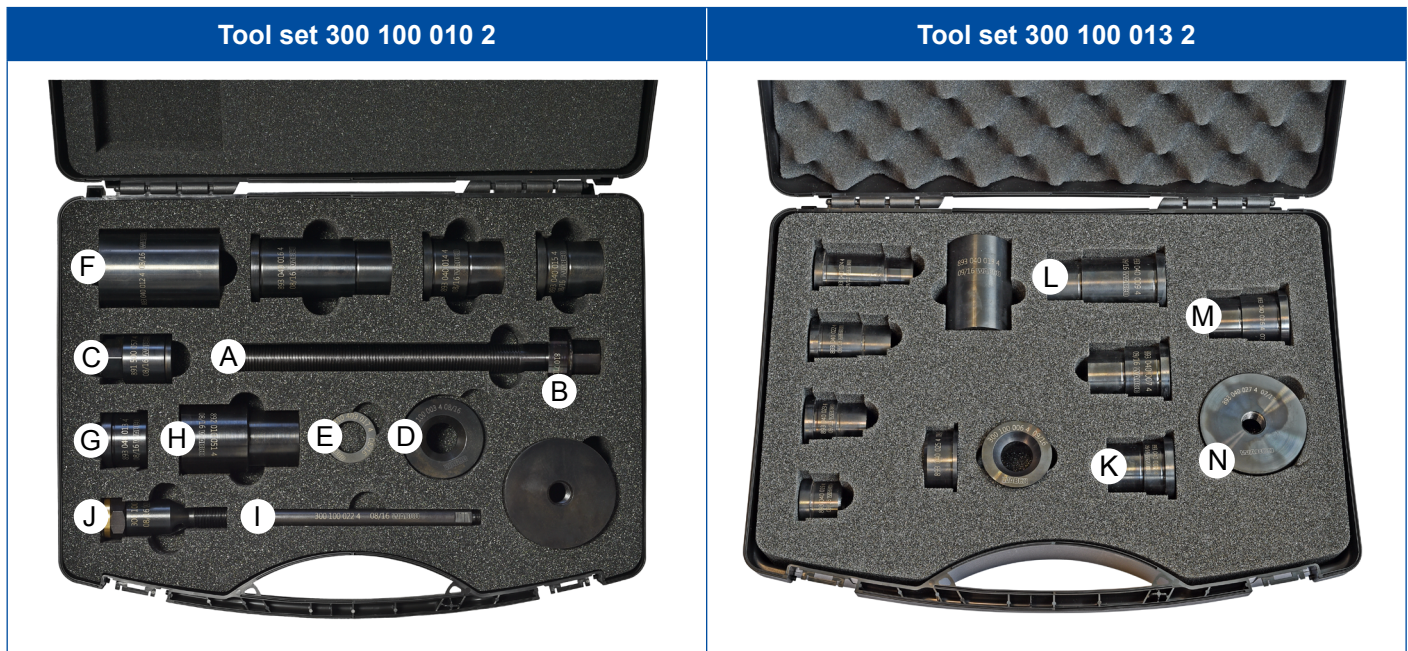

Item	Tools with application	Spanner width		Tightening torque (Nm)
		External	Internal	Remarks
I	Ring spanner for the hexagon on the shaft of the return unit	8	–	Direction of rotation on the hexagon: <ul style="list-style-type: none"> ■ Closing, anticlockwise (left) maximum 3 Nm, clearance decreases. ■ Restoring, clockwise (right), maximum 12 Nm, clearance increases.
II	Socket wrench for hexagon screw of the lining retainer clip	17	–	40 + 5 Nm
III	Socket wrench for bolting the brake to the axle adapter	24	–	i Follow the instructions of the axle or vehicle manufacturer.
IV	Socket wrench for the hexagon socket screws of the guide pin coupling	–	14	130 Nm +90° (torque angle tightening) Tightening sequence for guide pins: <ul style="list-style-type: none"> ■ 1. Guide pin long => fitted bolt (with hexagon socket screw) ■ 2. Guide pin short => clearance bolt (with hexagon socket screw)
V	Socket wrench for bolting the brake cylinder to the calliper	24	–	180 - 210 Nm (applies to original WABCO cylinders) <ul style="list-style-type: none"> ■ Thread on the fastening nuts by hand until the brake cylinder makes full contact. ■ Tighten the fastening nuts with approx. 120 Nm. ■ Tighten the fastening nuts with 180 -210 Nm. i Only use fastening nuts once.

6 WABCO tools

You will require the following tools to repair the PAN19 disc brake:



Item	 Tool designation	Item	 Tool designation
A	Threaded spindle TR 20x2 300 100 005 4	H	Drive-in sleeve cover 892 010 051 4
B	Thrust bearing 810 710 007 4	I	Holding rod 300 100 022 4
C	Nut TR 20x2 891 500 057 4	J	Connecting pin 300 100 007 2
D	Compensating washer 300 100 003 4	K	Press-in sleeve fitting pin, top 893 040 008 4
E	Round washer 810 409 017 4	L	Press-in sleeve fitting pin, bottom 893 040 009 4
F	Press-out sleeve 893 040 012 4	M	Press-in sleeve clearance bolt 893 040 026 4
G	Press-out pin 893 040 013 4	N	Press-in cup PAN 893 040 027 4

Tool set 300 100 012 2	Item	 Tool designation
	O	Ratchet for return unit 300 100 012 2

7 Checking the brake

7.1 Checking adjuster function





- The brake cylinder does not have to be dismantled in order to check the adjuster setting. The brake is shown without the brake cylinder for illustrative purposes only.
- To check the adjuster setting, the brake linings and pressure plate with the hold-down system, comprising the hold-down-springs, lining retainer clip and hexagon screw, must be installed.

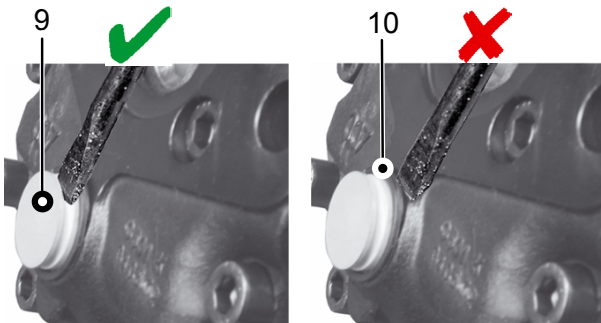

For this chapter, you require the following tools:

- **Ring spanner, size 8 (outside)** ▶ Page 12 (position I)
- **WABCO tool set 300 100 012 2** ▶ Page 13
- **Screwdriver**



1. Carefully remove the sealing plug of the return unit (9) from the calliper:
To avoid damaging the protective cap of the return device (10) or calliper (1), only set a  **screwdriver** against the seal of the return unit (9).
2. Check the sealing plug of the return unit (9) for wear and damage.

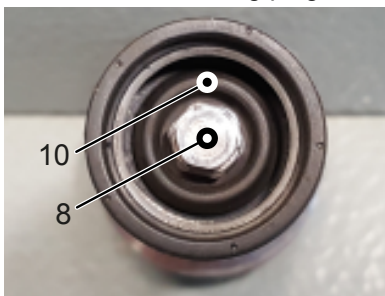

3. Check the return unit hexagon (8) and the seal of the return unit (10) for wear and damage.
4. Replace the seal (10) if you detect wear or damage ▶ Chapter "11.4 Replacing the return unit seal", page 51.

Checking the brake

NOTICE

Damage to the return unit hexagon screw from open-ended wrenches and motor-powered torque tools

The use of open-ended spanners and motor-powered torque tools can cause damage to the return unit hexagon screw.

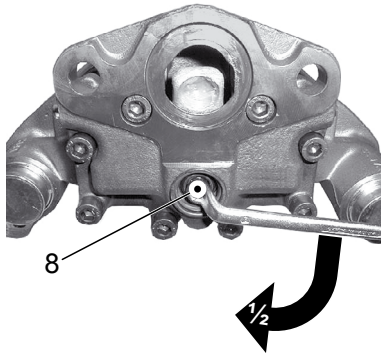

- Only use the tool recommended by WABCO .



- Using the  **ring spanner, size 8 (outside)**, turn the return unit hexagon screw (8) by a $\frac{1}{2}$ turn clockwise.



Checking the adjustment is only possible with a larger gap (2 to 3 mm).

- Adjust the clearance to 2 to 3 mm.
 - ⇒ There must be sufficient space for the applied tool ( **ring spanner, size 8 (outside)**) so that it is not obstructed when turning it during the adjustment. The tool is only used here as a visual aid so that the rotation of the return unit hexagon screw (8) is more clearly perceptible.
- Leave the  **ring spanner, size 8 (outside)** on the hexagon screw of the return unit (8) and lightly actuate the brake 5 times.
Make sure to use a ring spanner size 8 (outside).

OBSERVATION	Result
The tool rotates counterclockwise stepwise.	Proper function
The angle of rotation decreases with each actuation.	Proper function
The tool does not rotate.	Incorrect function ▶ Chapter "10 Replacing the brake", page 36.
The tool only rotates with the first actuation.	Incorrect function ▶ Chapter "10 Replacing the brake", page 36.
The tool rotates back and forth each time it is actuated.	Incorrect function ▶ Chapter "10 Replacing the brake", page 36.

- Remove the  **ring spanner, size 8 (outside)** from the return unit hexagon screw (8).
- Reset the clearance to 1.2 mm having completed the adjuster test ▶ Chapter "8.8 Adjusting the clearance", page 29.
- Place the sealing plug (9) on the return unit hexagon screw (8).
Make sure that it fits tightly.

7.2 Checking the brake linings



- Check the brake lining thickness at regular intervals in relation to the vehicle use, during maintenance intervals, as well as in the context of applicable local laws and regulations.
- The following checks can be conducted with the brake installed.

7.2.1 Visual check of the brake linings

- Immediately replace burnt, vitrified or oiled brake linings (23, 24) ▶ Chapter "8 Replacing the brake linings", page 23.

7.2.2 Measuring the brake lining wear



For this chapter, you require the following tools:

- **Measuring tape**

The average lining wear can be measured with a measuring tape (depending on the accessibility) either on the long guide pin (fitting pin) (3) or the short guide pin (clearance pin) (4).



1. For a measurement on the side of the clearance pin (4), place the measuring tape on the processed area on the brake carrier (2) next to the short guide pin (clearance pin) (4).

The measuring point on the brake carrier (2) is the processed area where the brake carrier (2) is screwed to the axle.

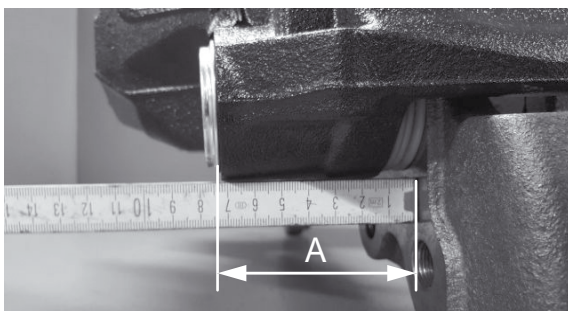

2. Measure the distance from the area on the brake carrier (2) to the edge of the short guide pin (clearance pin) (4) on the calliper (1).

⇒ The wear limit has been reached when the measured distance on the short guide pin (clearance pin) (4) is greater than 96 mm (A).

Checking the brake



3. For a measurement on the side of the fitting pin (3), place the measuring tape on the processed area on the brake barrier (2) next to the long guide pin (fitting pin) (3).

The measuring point on the brake carrier (2) is the processed area where the brake carrier (2) is screwed to the axle.

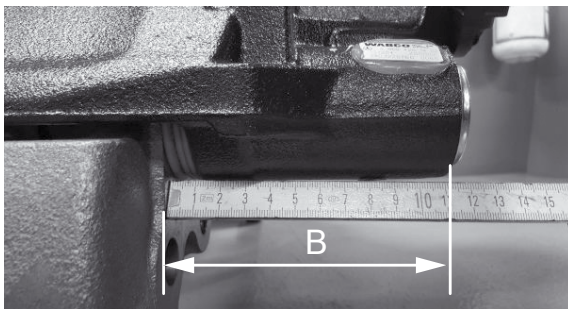

4. Measure the distance from the area on the brake carrier (2) to the edge of the long guide pin (fitting pin) (3) on the calliper (1).
 - ⇒ The wear limit has been reached when the measured distance on the long guide pin (fitting pin) (3) exceeds 122 mm (B).
5. Replace the brake linings (23, 24) if the wear limit has been reached or exceeded ▶ Chapter "8 Replacing the brake linings", page 23.
6. Check the brake disc ▶ Chapter "7.3 Checking the brake discs", page 19.

7.2.3 Measuring the thickness of the brake linings

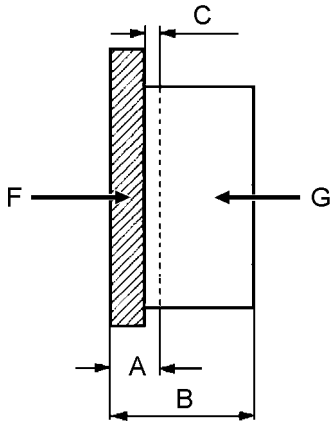

1. Measure the overall thickness of the brake carrier (F) and brake lining (G).

Legend	
A	Total thickness of worn brake lining with lining backing (limit value 11 mm)
B	Total thickness of new brake lining: 30 mm
C	Lining thickness without backing (limit value 2 mm residual thickness)
F	Friction material
G	Brake lining

2. To avoid damaging the brake disc, replace the brake linings (23, 24) no later than the time when they reach the wear limit at their weakest point.
The residual lining thickness must not be allowed to become less than 2 mm above the lining backing.
3. Replace the brake linings (23, 24) if the wear limit (**A < 11 mm**) has been reached or exceeded ▶ Chapter "8 Replacing the brake linings", page 23.

7.3 Checking the brake discs



- Check the brake discs at regular intervals and in accordance with vehicle use, maintenance intervals and legal requirements.
- The following checks can be conducted with the brake installed.

1. Remove the brake linings (23, 24) ▶ Chapter "8.3 Removing the brake linings", page 25.
2. Measure the brake disc thickness at the contact area of the brake linings (23, 24).

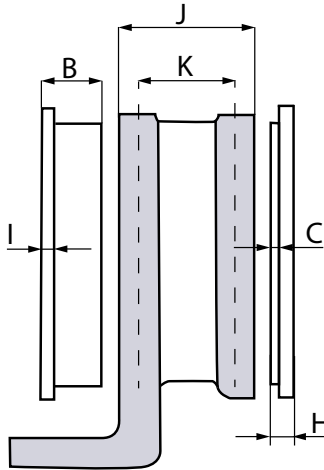

Legend

B	Total thickness of new brake lining: 30 mm
C	Minimum thickness of brake lining: 2 mm
H	Absolute minimum thickness and brake lining backing plate: 11 mm The brake linings must be replaced.
I	Brake lining backing plate: 9 mm
J	Total thickness of the brake disc: 45 mm
K	Wear allowance limit: 37 mm The brake disc must be replaced.

3. Replace the brake disc if the wear limit of 37 mm has been reached at the thinnest point.



- Only fit cleaned and grease-free brake discs.
- Always replace all brake discs on an axle.

7.3.1 Visual check of the brake discs

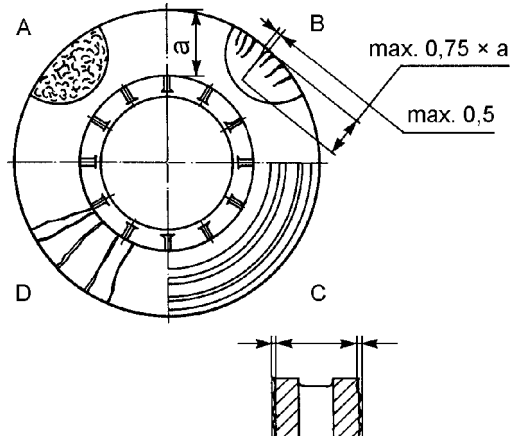

Legend

A	Web-like crack formation: permissible
B	Radial cracks up to max. 0.5 mm width: permissible
C	Irregularities of the disc surfaces up to max. 1.5 mm depth: permissible
D	Continuous cracks: not permissible
a	Width of the braking area

1. Check the brake disc for cracks and the condition of the surface.
2. Replace the brake disc if the brake disc shows continuous cracks or irregularities or if cracks exceed the maximum dimension.

7.3.2 Checking the brake disc run-out

1. Fasten the dial indicator to the brake carrier (2).

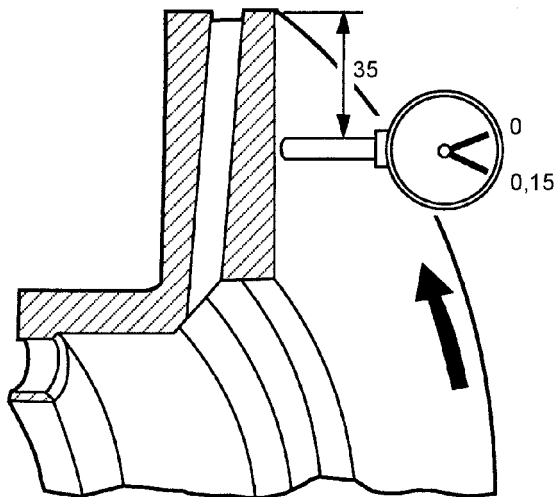

2. With the brake disc installed, check the disc run-out by rotating the wheel hub. Limit value: 0.15 mm
3. Replace the brake disc or have it properly remachined if the brake disc run-out is more than 0.15 mm.
4. Install the brake linings ▶ Chapter "8.7 Installing the brake linings", page 29.
5. Adjust the clearance ▶ Chapter "8.8 Adjusting the clearance", page 29.

7.4 Checking the bearing play of the guide pins

1. Remove the vehicle wheel in accordance with the instructions of the axle or vehicle manufacturer.
2. Remove the brake linings (23, 24) and the pressure plate (7) ▶ Chapter "8.3 Removing the brake linings", page 25.
3. Push the calliper (1) completely to the rim side by hand.
4. Fasten the magnetic dial indicator support to the brake carrier (2) or the axle.
5. Clean the measuring point.
The measuring point is the moulded edge on the calliper (1) on the rim side.

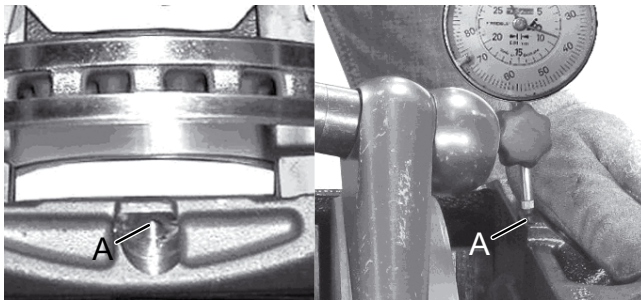

6. Press the dial indicator against the measuring point (A) on the calliper (1).

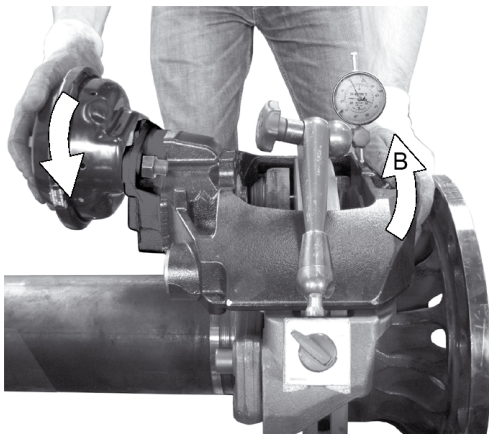

7. Tilt the calliper (1) as far as possible using minimal force (arrow B).
8. Set the dial indicator to zero.



9. Now lightly tilt the calliper (1) as far as possible in the opposite direction using minimal force (arrow C).

Checking the brake

10. Read off the dial indicator.
 - ⇒ The bearing play must not be greater than 2 mm.
11. Replace the bushings of the guide pins (22A and 22B) if the measured bearing play is greater than 2 mm ▶ Chapter "11.1 Replacing the closure caps and the bushings of the guide pins", page 39.
12. Remove the measuring device (dial indicator including magnetic support).
13. Install the pressure plate (7) and brake linings (23, 24) ▶ Chapter "8.7 Installing the brake linings", page 29.
14. Adjust the clearance ▶ Chapter "8.8 Adjusting the clearance", page 29.
15. Continue with ▶ Chapter "12 Final activities", page 54.

8 Replacing the brake linings

8.1 Preparatory activities

- For this chapter, you require the following tools:
- **Socket spanner, size 17 (outside)** ▶ Page 12 (position II)
 - **Ring spanner, size 8 (outside)** ▶ Page 12 (position I)
 - **WABCO tool set 300 100 012 2** ▶ Page 13
 - **Screwdriver**

1. Remove the vehicle wheel in accordance with the instructions of the axle or vehicle manufacturer.

⚠ CAUTION

Risk of injury to fingers and hands

Holding the brake on the inside surface may cause injury to fingers and hands.

- *Always hold the brake at the outer edges.*

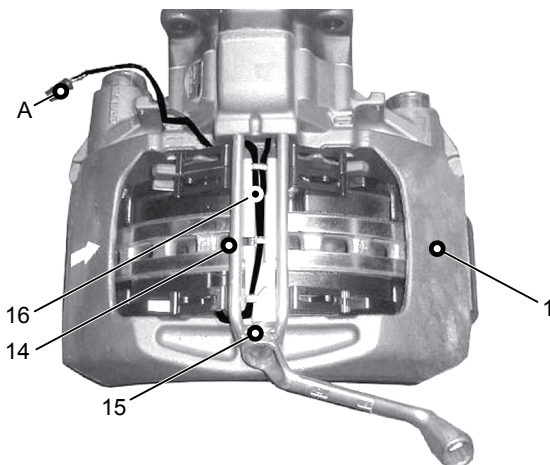

2. Disconnect the plug connector (A) for the wear indicator (16).
3. Using a **socket spanner, size 17 (outside)**, unscrew the hexagon socket screw (15) from the lining retainer clip (14), while applying pressure on the lining retainer clip (14) with your hand.
4. Pull the lining retainer clip (14) out of the calliper (1).

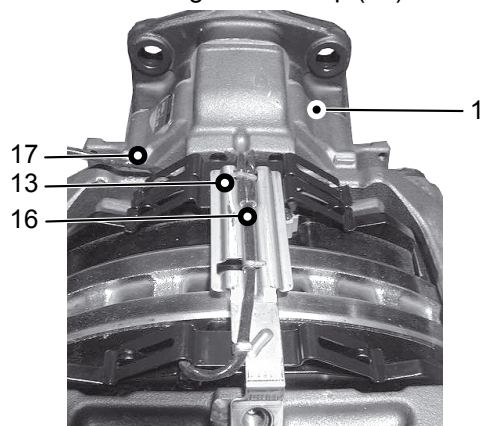

5. Remove the cable guide plate (13) from the wear indicator (16).
6. Remove the cable clips (17) from the calliper (1).

Replacing the brake linings

WARNING

Risk of accident from damaged brakes

The seal on the return unit or calliper may be damaged if the screwdriver is inserted incorrectly. Dirt or moisture can penetrate into the brake and damage it. This can cause the brake system to fail.

- Only apply  the screwdriver to the sealing plug on the return unit.

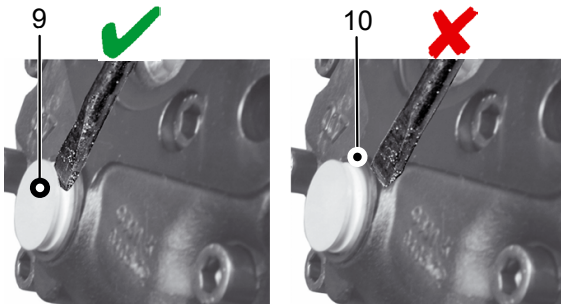

7. Carefully remove the sealing plug of the return unit (9) from the calliper (1).
8. Check the seal of the return unit (10) for wear and damage.
9. Replace the seal of the return unit (10) if you detect any wear or damage ▶ Chapter "11.4 Replacing the return unit seal", page 51.

8.2 Resetting

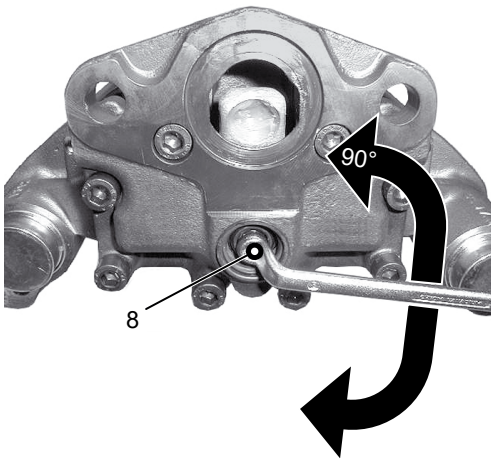

10. Using the  ring spanner, size 8 or the **WABCO tool O**, turn the return unit hexagon screw (8) clockwise to the end stop.
11. Turn the hexagon of the return unit (8) 90° counterclockwise.

8.3 Removing the brake linings

⚠ CAUTION

Risk of injury from applying the brakes with the brake linings removed

Operating the brakes with the brake linings removed while performing repair work on the brake may result in injury.

- *Attach a warning notice to the steering wheel to indicate that work is being performed on the vehicle and that the brake must not be applied.*

1. Remove the vehicle wheel in accordance with the instructions of the axle or vehicle manufacturer.



- The brake cylinder does not have to be dismantled in order to replace the brake linings.
- Always replace the brake linings axle-wise and use a new retaining system comprising a retainer clip, hexagon socket screw and hold-down springs. The hold-down springs are already pre-assembled on the brake linings.

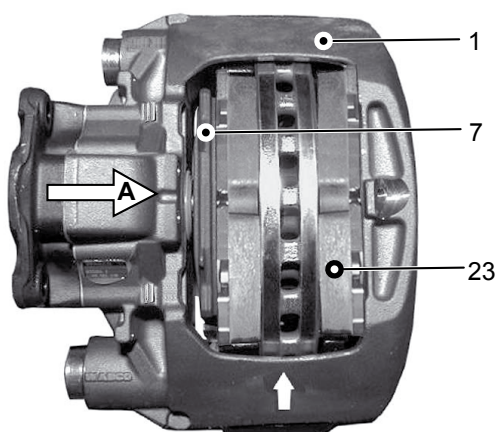

2. Push the calliper (1) by hand towards the **rim side (arrow A)**.
3. Remove the brake lining (23) on the **rim side (arrow A)**.

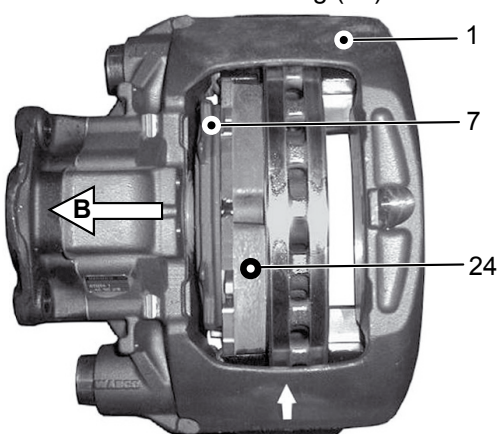

4. Push the calliper (1) by hand towards the **cylinder side (arrow B)**.
5. Remove the brake lining (24) on the **cylinder side (arrow B)**.

Replacing the brake linings

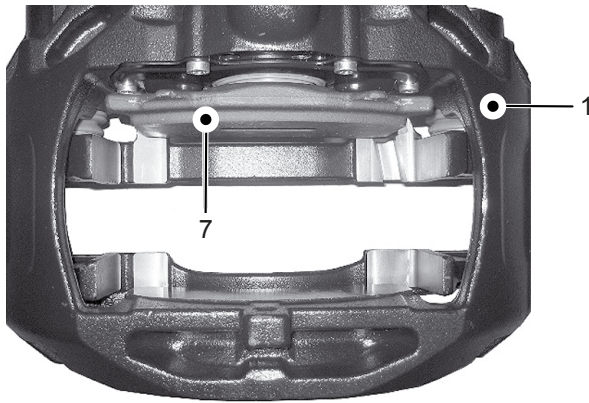

6. Take the pressure plate (7) out of the calliper (1).
7. Check the pressure plate (7) for damage.
8. Replace the pressure plate (7) if you notice any damage.
9. Check the pressure plate (7) for corrosion.

WARNING

Risk of accident from damaged brakes

Improper cleaning (e.g. using a wire brush) may damage the protective pin caps and the plunger cap. Dirt or moisture can penetrate into the brake and damage it. This can cause the brake system to fail.

- *Clean the protective pin caps and the plunger cap properly.*

10. Use a wire brush to clean pressure plate (7), lining slots and pressure plate guide on the calliper (1) and remove any corrosion from these components.
11. Make sure that the guide surfaces of the lining slots on the brake carrier (2) are clean and free of grease.

8.4 Checking the movement of the calliper

- 🔧 For this chapter, you require the following tools:
- Ring spanner, size 8 (outside) ▶ Page 12 (position I)
 - WABCO tool set 300 100 010 2 ▶ Page 13

⚠️ WARNING

Risk of accident from damaged brakes

When the calliper moves, the protective pin caps can get squeezed against the brake carrier.

Dirt or moisture can penetrate into the brake and damage it. This can cause the brake system to fail.

- Make sure that the protective pin caps do not get squeezed against the brake carrier.

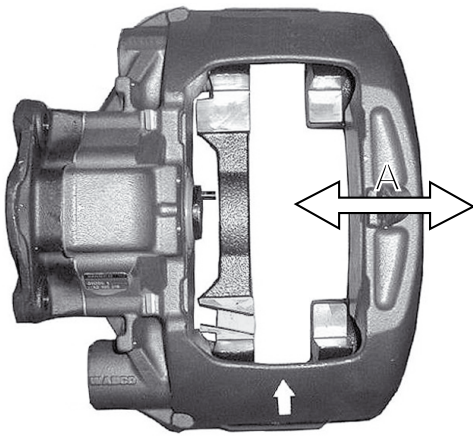

1. Move the calliper (1) by hand along the entire length of the guide pins (3, 4) and check that it moves easily (A).
2. Replace the bushings (22), guide pins (3, 4), hexagon socket screws (6) and closure caps (11.1 and 11.2) if the calliper (1) does not move smoothly ▶ Chapter "11.1 Replacing the closure caps and the bushings of the guide pins", page 39.
3. Push the calliper (1) towards the cylinder side by hand.

8.5 Checking the protective pin caps

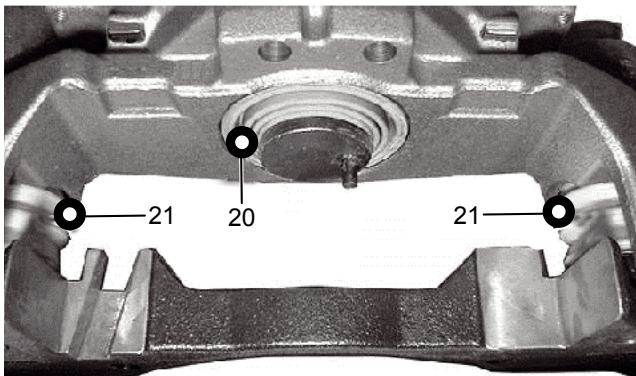

1. Check the protective pin cap (21) for wear and damage.
2. Replace any defective protective pin caps (21) ▶ Chapter "11.2 Replacing the protective pin caps", page 42.

NOTICE

Damage to the return unit hexagon screw

Using open-ended spanners and motor-powered torque tools can cause damage to the return unit hexagon screw.

– Only use a  ring spanner, size 8 (outside), or the **WABCO tool O**.

1. Use the  ring spanner, size 8 (outside) or the **WABCO tool C** to turn the return unit hexagon nut (8) clockwise until the adjusting screw (5) protrudes by about 30 mm.
2. Check the plunger cap (20) for wear and damage.
3. If the plunger protection cap (20) is damaged, check whether any dirt or moisture that has already penetrated has damaged the internal parts of the brake or the seal seat in the brake calliper (1) due to corrosion.
4. Replace the brake if you notice any damage or corrosion ▶ Chapter "10 Replacing the brake", page 36.
5. Replace the plunger cap (20) if it is already damaged or it gets damaged during service work on the brake ▶ Chapter "11.3 Replacing the plunger cap", page 46.

8.6 Installing the pressure plate

1. Insert the pressure plate (7) into the brake carrier (2).
2. Slide the pressure plate (7) up against the adjusting screw (5).
 - ⇒ The pin of the adjusting screw (5) must engage in the groove in the pressure plate (7) otherwise the return unit cannot function.

NOTICE

Damage to the plunger cap

The plunger cap can get damaged if the pin of the adjusting screw slips out of the retaining groove in the pressure plate as the plunger cap will then turn together with the adjusting screw.

– While turning the hexagon nut, push the pressure plate by hand towards the cylinder side so that the pin, as a twist lock, does not slip out of the retaining groove in the pressure plate. This prevents the adjusting screw from turning as well as the plunger cap from turning with it.

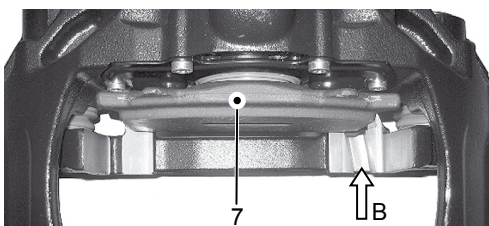

3. Turn the adjusting screw (5) until the pin engages in the groove in the pressure plate (7). Make sure that the plunger cap (20) is not twisted.
 - ⇒ The pressure plate (7) must sit in the guide groove (arrow B) in the brake carrier (2) and make contact over the entire area of the guide strips of the brake carrier (2). Otherwise the pressure plate (7) could slide out of the guide.

8.7 Installing the brake linings



Pay attention to the notes on installing the pressure plate ▶ Chapter "8.6 Installing the pressure plate", page 28.

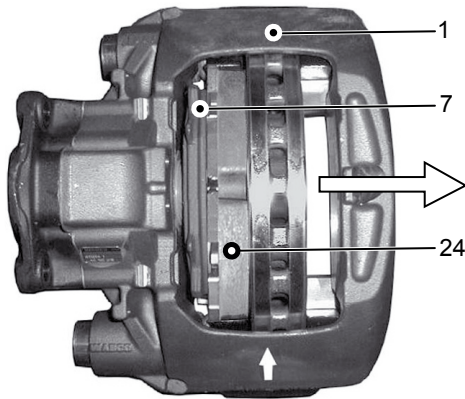

1. Fit a **new** brake lining (24) on the cylinder side.
2. Push the calliper (1) towards the rim side until the brake lining on the cylinder side (24) bears against the brake disc.
3. Fit a **new** brake lining (23) on the **rim side**.



Do not mount the lining retainer clip until you have adjusted the clearance.

8.8 Adjusting the clearance



For this chapter, you require the following tools:

- **Ring spanner, size 8 (outside)** ▶ Page 12 (position I)
- **WABCO tool set 300 100 010 2** ▶ Page 13
- **Feeler gauge**

1. Slide a 0.9 mm thick feeler gauge in the middle between the back of the brake lining on the cylinder side (24) and the pressure plate (7).

NOTICE

Damage to the return unit hexagon screw

Using open-ended spanners and motor-powered torque tools can cause damage to the return unit hexagon screw.

- Only use a  **ring spanner, size 8 (outside)**.

2. Using the  **ring spanner, size 8 (outside)** turn the return unit hexagon nut (8) counterclockwise until both brake linings (23, 24) are lying against the brake disc.
3. Remove the feeler gauge.

8.9 Laying the sensor cable

 For this chapter, you require the following tools:
■ **Socket spanner, size 17 (outside)** ▶ Page 12 (position II)

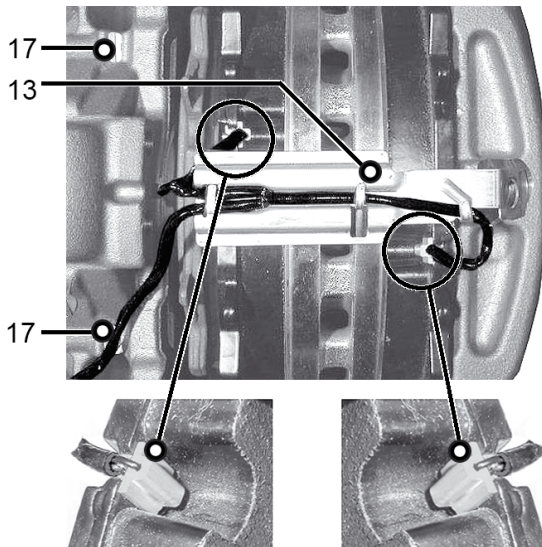

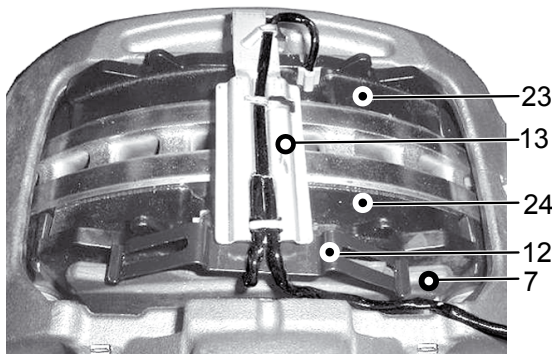

1. Fit two **new** spring clips (17) in the calliper (1).
2. Place the **new** cable guide plate (13) with the **new** pre-assembled wear indicators (16) on the calliper (1) and insert the wear indicator (circles) into the brake linings (23, 24).
Make sure that the wear indicator is fully inserted into the brake linings (23, 24) and points with the wear side towards the brake disc.

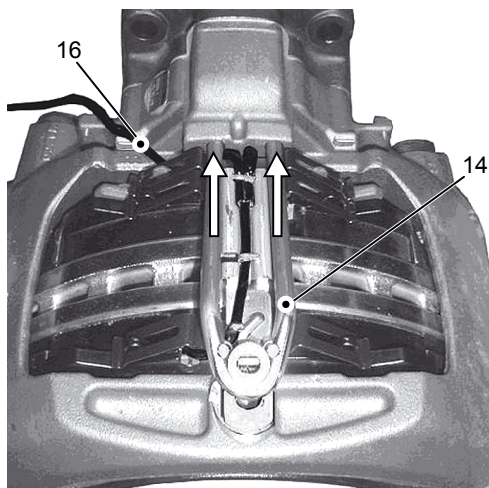

3. Lift up the cable guide plate (13) a short distance.
4. Push three **new** hold-down springs (12) underneath the cable guide plate (13) and onto the brake linings (23, 24) and the pressure plate (7).
When laying the cable, make sure that it does not touch the brake lining on the cylinder side (24).
5. Press the cable guide plate (13) against the hold-down springs (12).
6. Position the cable guide plate (13) on the calliper (1).

Replacing the brake linings



7. Push a **new** lining retainer clip (14) into the openings (▶ white arrows) of the calliper (1).
8. Press down the lining retainer clip (14) so that it engages between the radial lugs of the hold-down springs (12).
Make sure that the lining retainer clip (14) is positioned above the wear indicator cables (16).
9. Using a  **socket spanner, size 17 (outside)**, secure a **new** hexagon socket screw (15) to the calliper (1). **Tightening torque: 40 + 5 Nm**

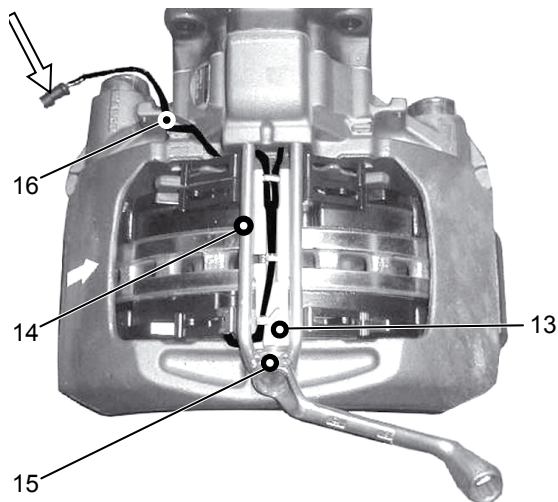

10. If fitted, remove the protective transport cap from the wear indicator (16) connector (▶ white arrow).
11. Plug the connector (▶ white arrow) of the wear indicator (16) into the socket on the vehicle or the axle socket.
12. Fasten the cable to the **new** cable clip (17).
13. Check that the cable is correctly routed.
14. Fix the cables into position using cable ties.
15. Mount the connector of the wear indicator (16) on the connector retaining plate (19).

Replacing the brake linings

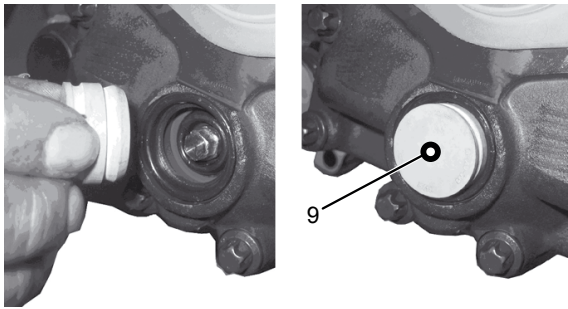

16. Push a **new** return unit sealing plug (9) into the opening of the calliper (1).
Make sure that the return unit sealing plug (9) is fitted tightly.
17. Check that the wheel hub moves freely.
18. Continue with ► Chapter "12 Final activities", page 54.

9 Replacing the brake cylinder

9.1 Removing the brake cylinder

🔧 For this chapter, you require the following tools:

- **Socket spanner, size 24 (outside)** ▶ Page 12 (position III)

1. Disconnect the air supply to the vehicle before carrying out this work.
2. Make sure that the connecting lines are disconnected before you remove the diaphragm cylinder.

⚠️ WARNING

Risk of accident from damaged brakes

Dirt or moisture can penetrate into the brake and damage it. This can cause the brake system to fail.

- *Make sure that no dirt or moisture penetrates into the brake when removing the brake cylinder.*

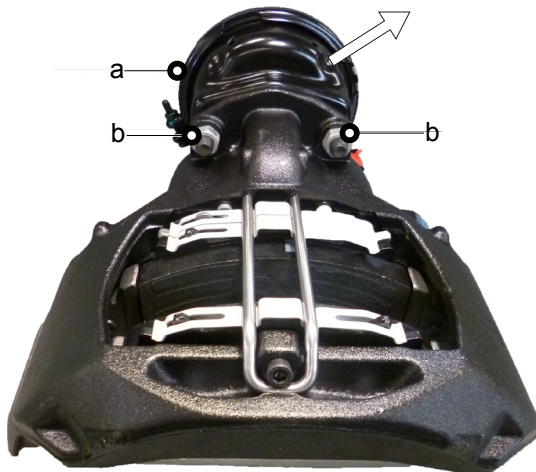

3. Unscrew the air connection (a) from the brake cylinder in accordance with the brake cylinder manufacturer's specifications.
4. Use a 🔧 **socket spanner, size 24 (outside)** to unscrew the brake cylinder nuts (b).
5. Remove the brake cylinder from the calliper (1).

9.2 Installing the brake cylinder

🔑 For this chapter, you require the following tools:
■ **Socket spanner, size 24 (outside)** ▶ Page 12 (position III)

⚠️ WARNING

Risk of accident from damaged brakes

Dirt or moisture can penetrate into the brake and damage it. This can cause the brake system to fail.

– *Make sure that no dirt or moisture penetrates into the brake when installing the brake cylinder.*

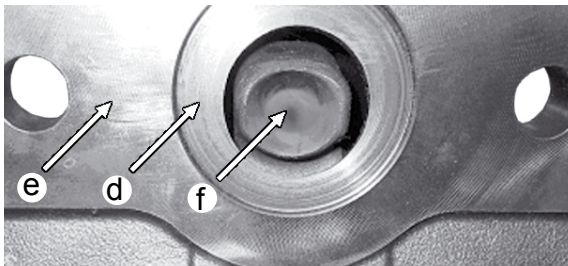

1. Clean the sealing surface (d) and flange area (e) on the calliper (1).
2. Grease the spherical cap in the brake lever (f) before installing the brake cylinder.
3. Place the brake cylinder against the calliper (1).
 - ⇒ Depending on the installation position of the brake, make sure that the lower drainage aperture of the brake cylinder facing the ground is open.
 - ⇒ Depending on the brake cylinder type, the other drainage openings can either remain open or they must be sealed with a plug.

Always use **new** fastening nuts when fitting the brake cylinder.

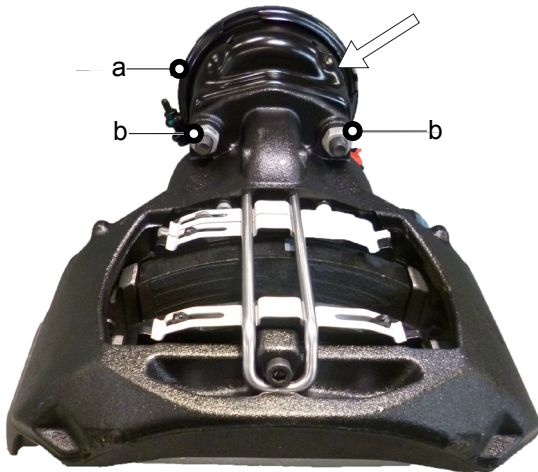

4. Screw **new** fastening nuts (b) onto the brake cylinder by hand until the brake cylinder fully rests on the calliper (1).
5. Using a 🔑 **socket wrench, size 24 (outside)**, tighten the brake cylinder symmetrically to prevent it from tilting. **Tightening torque: 120 Nm**
6. Tighten the fastening nuts (b) using a 🔑 **socket wrench, size 24 (outside)**.
Tightening torque: 180 - 210 Nm
7. Screw the air connection (a) onto the brake cylinder.

WARNING

Risk of accident from damaged brake lines

If installed incorrectly, the brake lines can be damaged or bent, or rub against other components. This can cause the brake system to fail.

- *Install the brake lines without twisting them.*
- *Install the brake lines so that they do not rub against other parts.*

8. Make sure that the brake hose does not exert any initial stress on the sliding function of the calliper (1).
9. Make sure that the movement of the calliper (1) is not obstructed over its entire displacement path.
10. Check the air connection for leaks according to the brake cylinder manufacturer's specifications.
11. Continue with ► Chapter "12 Final activities", page 54.

10 Replacing the brake

10.1 Removing the brake

 For this chapter, you require the following tools:
■ **Socket spanner, size 24 (outside)** ▶ Page 12 (position III)

WARNING

Risk of accident due to damaged lining retainer clip

Using the lining retainer clip as a handhold or for fastening the brake to a lifting device can damage it. The brake linings can no longer be held in position if the lining retainer clip breaks or gets bent. There is a risk of accident.

– *Never use the lining retainer clip as a handhold or for fastening the brake to a lifting device.*

1. Remove the vehicle wheel in accordance with the instructions of the axle or vehicle manufacturer.
2. Remove the brake cylinder from the calliper (1) ▶ Chapter "9.1 Removing the brake cylinder", page 33.
3. Disconnect the plug connector for the wear indicator (16).
4. Remove the brake linings (23, 24) ▶ Chapter "8.3 Removing the brake linings", page 25.

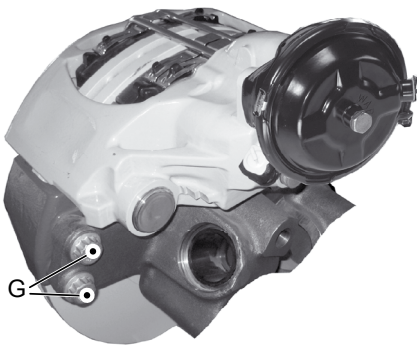

5. Unscrew the fastening screws (G).

CAUTION

Risk of crushing fingers and hands

When dismantling the calliper with brake carrier from the axle, there is a risk of crushing your fingers and hands.

– *Make sure not to crush your fingers and hands.*

6. Using a  **socket spanner, size 24 (outside)**, remove the calliper (1) with brake carrier (2) from the axle.
7. Check the brake disc ▶ Chapter "7.3 Checking the brake discs", page 19.
8. Check the removed brake linings (23, 24).
9. Replace the brake linings (23, 24) as required ▶ Chapter "7.2.3 Measuring the thickness of the brake linings", page 18.
10. Check the fastening flange on the axle for wear and damage.
11. Clean the fastening flange of any dirt, rust and grease.

10.2 Installing the brake

 For this chapter, you require the following tools:

- **Socket spanner, size 24 (outside)** ▶ Page 12 (position III)

1. Remove all transport locks from the **new** brake.

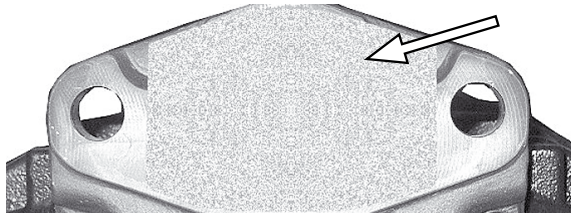

2. Completely remove the protective film (▶ white arrow), or the protective transport cap, in the vicinity of the cylinder mounting from the calliper (1).



- The **new** brake without brake lining is supplied as a pre-assembled unit and can be mounted to the vehicle's axle via the brake carrier.
- Left and right brakes must not be interchanged when they are installed on the axle. An arrow on the calliper indicates which brake is correct for the left and right sides of the axle. This arrow indicates the brake disc's direction of rotation when driving forwards. The diagonal wear compensation groove in the carrier is always mounted on the running-in side.

3. Place the **new** brake with brake carrier (2) over the brake disc.
4. Install the brake on the axle in accordance with the instructions of the axle or vehicle manufacturer.
5. Tighten the bolts using a  **socket wrench, size 24 (outside)**.
6. Install the pressure plate (7), brake linings (23, 24) and wear indicators (16) ▶ Chapter "8.6 Installing the pressure plate", page 28 and ▶ Chapter "8.7 Installing the brake linings", page 29.
7. Plug the connector of the wear indicator (16) into the socket on the vehicle or the axle socket.
8. Fasten the cable to the cable clip (17) of the calliper (1).
9. Check that the cable is correctly routed.
10. Fix the cables into position using cable ties.
11. Mount the connector of the wear indicator (16) on the connector retaining plate (19).
12. Adjust the clearance ▶ Chapter "8.8 Adjusting the clearance", page 29.

WARNING

Risk of accident due to defective brake cylinder

A defective brake cylinder can cause a braking system failure and must never be installed.

- *If you notice any damage, replace the brake cylinder.*

13. Check the brake cylinder for damage, particularly at the inner area of the piston rod seal.
14. Replace the brake cylinder if you notice any damage ▶ Chapter "9 Replacing the brake cylinder", page 33.

WARNING

Risk of accident from damaged brakes

Dirt or moisture can penetrate into the brake and damage it. This can cause the brake system to fail.

- *Make sure that no dirt or moisture penetrates into the brake when cleaning the brake cylinder.*

15. Clean the sealing surface and the flange area of the brake cylinder.

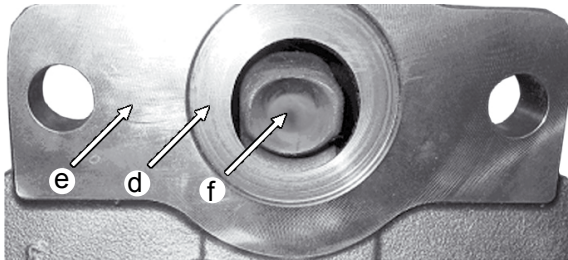

16. Clean the sealing surface (d) and flange area (e) on the calliper (1).

17. Grease the spherical cap in the brake lever (f).

18. Install the brake cylinder on the calliper (1) in accordance with the instructions of the brake cylinder manufacturer ▶ Chapter "9.2 Installing the brake cylinder", page 34.

- ⇒ Depending on the installation position of the brake, make sure that the lower drainage aperture of the brake cylinder facing the ground is open.
- ⇒ Depending on the brake cylinder type, the other drainage openings can either remain open or they must be sealed with a plug.

19. Check that the wheel hub moves freely.

20. Continue with ▶ Chapter "12 Final activities", page 54.

11 Replacing the seals



- If all the seals on the calliper are to be replaced, the work steps for replacing the closure caps and the bushings of the guide pins and plunger cap can be performed together.
- If the seals are only to be replaced separately, however, the work steps are to be performed as described in the following chapters:
 - ▶ Chapter "11.1 Replacing the closure caps and the bushings of the guide pins", page 39
 - ▶ Chapter "11.3 Replacing the plunger cap", page 46

11.1 Replacing the closure caps and the bushings of the guide pins

11.1.1 Disassembling the bushings



For this chapter, you require the following tools:

- **Socket spanner, size 24 (outside)** ▶ Page 12 (position III)
- **Socket spanner, size 14 (inside)** ▶ Page 12 (position IV)
- **WABCO tool set 300 100 010 2** ▶ Page 13
- **Chisel** or **screwdriver**

WARNING

Risk of accident due to damaged lining retainer clip

Using the lining retainer clip as a handhold or for fastening the brake to a lifting device can damage it. The brake linings can no longer be held in position if the lining retainer clip breaks or gets bent. This can cause the brake system to fail.

- *Never use the lining retainer clip as a handhold or for fastening the brake to a lifting device.*

1. Remove the vehicle wheel in accordance with the instructions of the axle or vehicle manufacturer.
2. Remove the brake cylinder from the calliper (1) ▶ Chapter "9.1 Removing the brake cylinder", page 33.
3. Disconnect the plug connector on the wear indicator (16).
4. Remove the brake linings (23, 24) ▶ Chapter "8.3 Removing the brake linings", page 25.

CAUTION

Risk of crushing fingers and hands

After loosening the calliper, there is a risk of crushing your fingers and hands.

- *Make sure not to crush your fingers and hands.*

5. Using a **socket spanner, size 24 (outside)**, remove the calliper (1) with brake carrier (2) from the axle ▶ Chapter "10.1 Removing the brake", page 36.
6. Use a suitable fastening device (e.g. vice) to clamp the brake to the brake carrier (2).

Replacing the seals

WARNING

Risk of accident from damaged brakes

Holes can be damaged if the tools are used incorrectly. Never place a tool (e.g. chisel) on the end surface of the calliper.

Dirt or moisture can penetrate into the brake and damage it. This can cause the brake system to fail.

- Only attach the tool (e.g. chisel) to the closure cap.

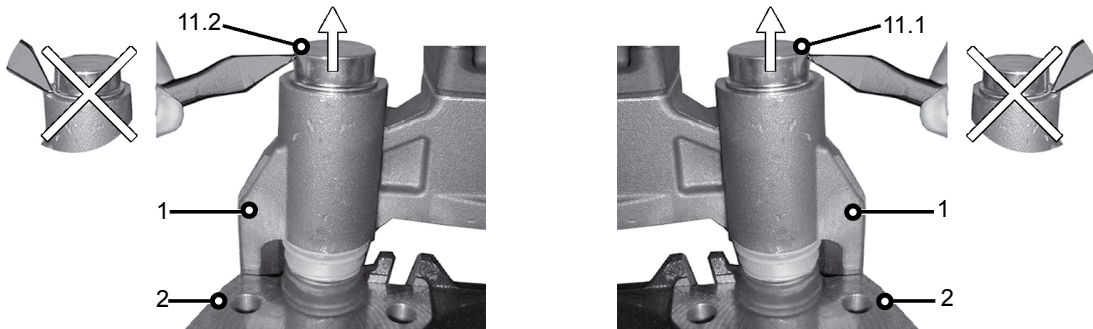

7. Use a  **chisel** or **screwdriver**, to remove the closure caps (11.1 and 11.2) from the calliper (1).

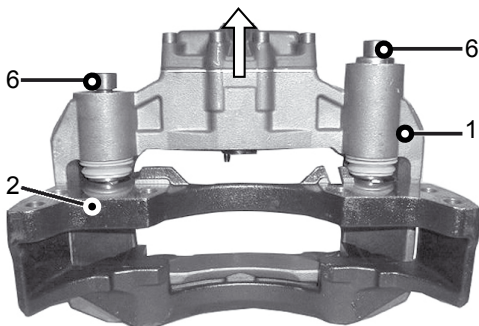

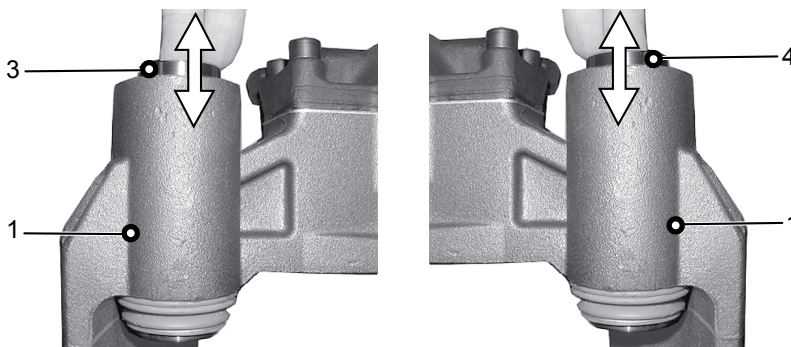

8. Loosen the hexagon socket screws (6) using a  **socket wrench, size 14 (inside)**.
9. Remove the calliper (1) from the brake carrier (2).
10. Clean the contact areas (fitting collar) to the guide pins (3, 4) on the brake carrier (2).

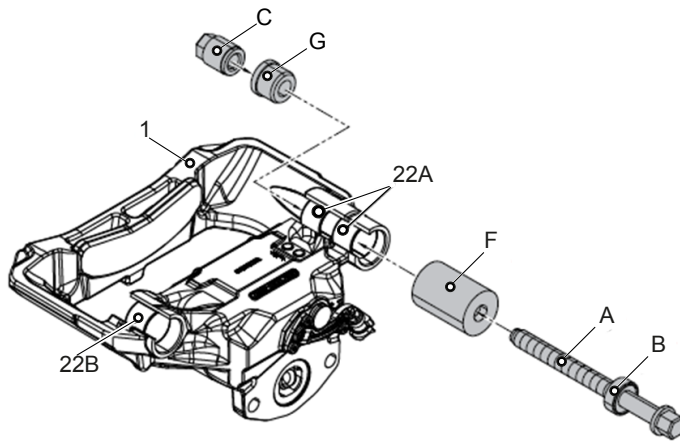

11. Remove the guide pins (3, 4) from the calliper (1).
12. Pull the protective pin caps (21) out of the ring groove in the calliper (1).
13. To press out the bushings of the guide pins (22), place the calliper (1) on a firm surface.
⇒ The back of the calliper (1) must face upwards.

Replacing the seals



14. Using the  **WABCO tools A, B, C, F and G**, press the bushings (22A) of the long guide pin (fitting pin) (3) and the bushing (22B) of the short guide pin (clearance pin) (4) out of the calliper (1).
15. Clean the holes in the calliper (1).

11.1.2 Mounting the bushings

 For this chapter, you require the following tools:

- **Socket spanner, size 24 (outside)** ▶ Page 12 (position III)
- **Socket spanner, size 14 (inside)** ▶ Page 12 (position IV)
- **WABCO tool set 300 100 010 2**
- **WABCO tool set 300 100 013 2**
- **Rubber hammer**



Note the differences between the brake versions. The position of the long guide pin (fitting pin) depends on the brake variant and the installation situation, and can be located on both the run-in and run-out sides of the brake disc.

1. Grease the sliding surfaces of the bushings (22A and 22B).
Press in two **new** bushings (22A) for the long guide pin (fitting pin) (3):

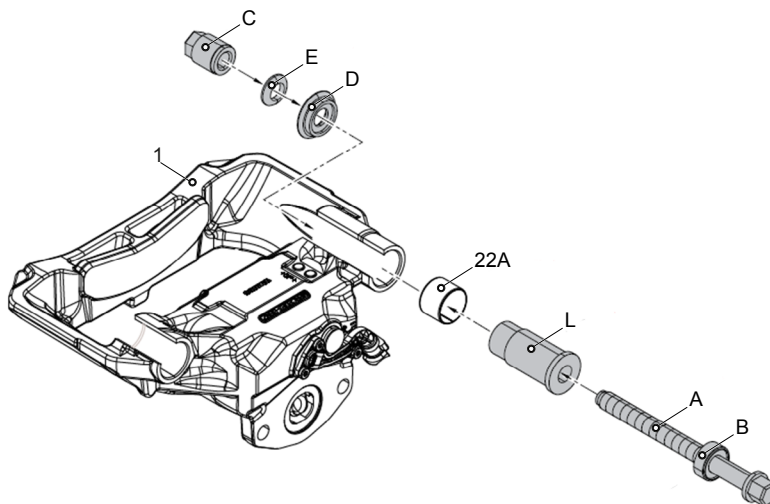

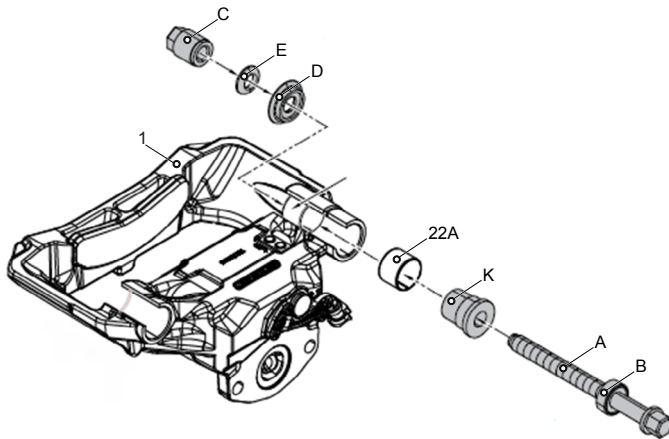

2. Using the  **WABCO tools A, B, C, D, E and L**, press the **inner** bushing (22A) into the holes in the calliper (1) up to the end stop of the tool.

Replacing the seals

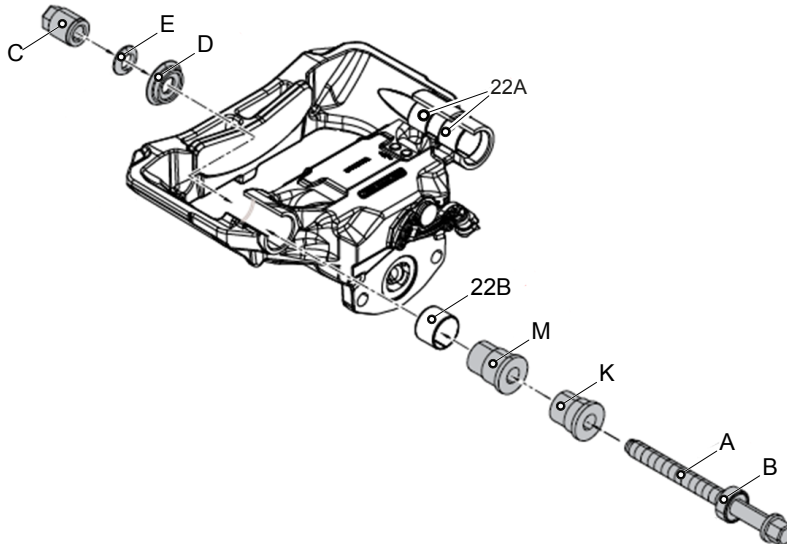

3. Using the  **WABCO tools A, B, C, D, E** and **K**, press the **outer** bushing (22A) into the holes in the calliper (1) up to the end stop of the tool.
⇒ The two bushings (22A) do not lie flush against one another.



4. Using the  **WABCO tools A, B, C, D, E, K** and **M**, press a **new** bushing (22B) for the short guide pin (clearance pin) (4) into the hole in the calliper (1) up to the end stop of the tool.

11.2 Replacing the protective pin caps

 For this chapter, you require the following tools:

- **WABCO tool set 300 100 010 2** and **WABCO tool set 300 100 013 2**

1. Clean the seal seats (ring groove) of the calliper (1) for the protective pin caps (21).
⇒ The cleaned seal seats must be clean and free of grease.

Replacing the seals

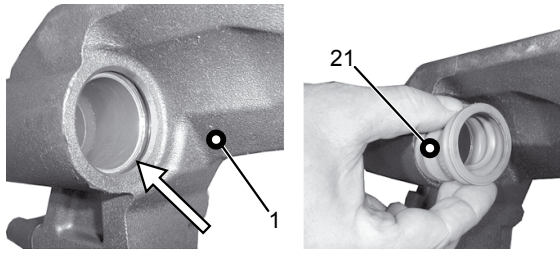

2. Press two **new** protective pin caps (21) by hand into the seal seats/ring groove (▶ white arrow) of the calliper (1).
3. Grease the bearing surfaces of the guide pins (3, 4) and the beaded edge of the protective pin caps (21).
Make sure that the protective pin caps (21) lie evenly and without creasing in the seal seat of the calliper (1).
4. Insert the two **new** guide pins (3, 4) into the calliper (1) from the cylinder side.
Insert the longer guide pin (3) into the long guideway with the two bushings (22A).
Insert the shorter guide pin (4) into the short guideway (22B).
5. Push the protective pin caps (21) over the guide pins (3, 4).

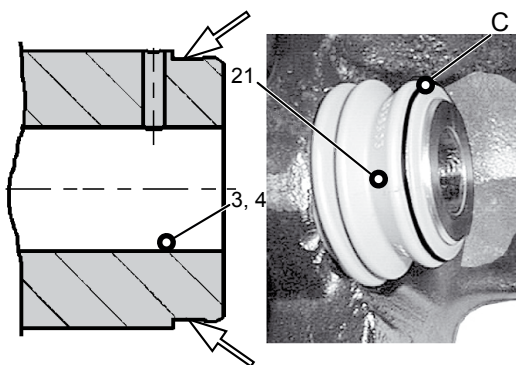

6. Position the beaded edge of the protective pin caps (21) into the seal seats (ring groove) of the guide pins (3, 4).
Make sure that the metal ring (C) does not get detached from the protective pin cap.
Make sure that the beaded edge of the protective pin caps (21) lies evenly and without creasing in the seal seats of the guide pins (3, 4).
7. Remove any excess grease.
⇒ The flat surfaces of the guide pins (3, 4) to the brake carrier (2) and the contact areas of the brake carrier (2) must be **clean and free of grease**.

WARNING

Risk of accident from damaged brakes

When the calliper moves, the protective pin caps can get squeezed against the brake carrier.

Dirt or moisture can penetrate into the brake and damage it. This can cause the brake system to fail.

– *Make sure that the protective pin caps do not get squeezed against the brake carrier.*

Replacing the seals

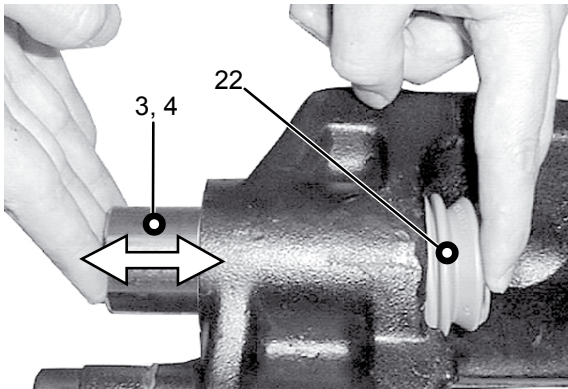

8. Move the guide pins (3, 4) lightly back and forth in the bushings (22) and check their ease of movement.
9. Place the calliper (1) on the brake carrier (2) and the inserted guide pins (3, 4) into the fitting collar.

WARNING

Risk of accident from damaged brakes

The protective pin caps can get damaged during the assembly.

Dirt or moisture can penetrate into the brake and damage it. This can cause the brake system to fail.

- *During the assembly, make sure that the protective pin caps do not get damaged and avoid twisting them while tightening the hexagon socket screws.*

10. Insert two **new** hexagon socket screws (6) through the guide pins (3, 4) inserted in the calliper (1).
Always tighten the longer press-fit guide pin (fitting pin) (3) first, and then the short guide pin (4) with clearance (clearance pin).
If the guide pins (3, 4) are released from the brake carrier (2) during the maintenance work, you must use **new** hexagon socket screws (6) for the assembly.

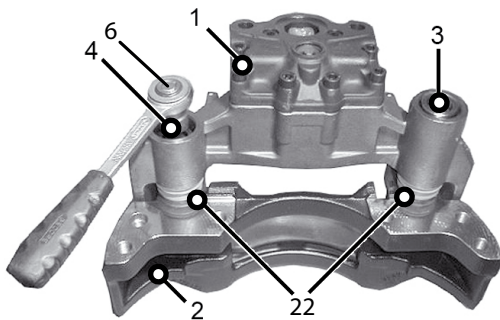

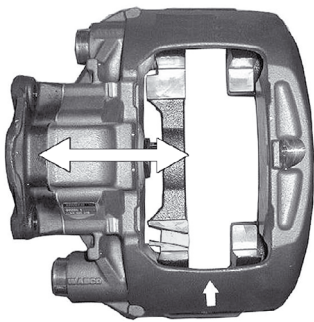

11. Using a  **socket spanner, size 14 (inside)**, loosen the hexagon socket screws (6) on the brake carrier (2).
Tightening torque: 130 Nm +90° (torque angle tightening)

Replacing the seals

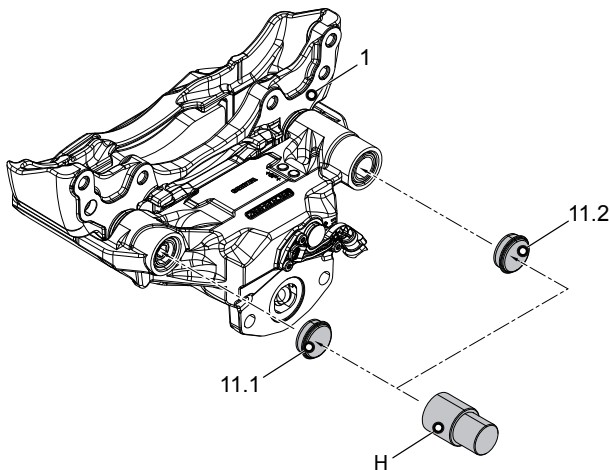

12. Move the brake calliper (1) several times by hand onto the guide pins (3, 4) over the entire travel to check that the movement is smooth.
13. Grease the holes for the closure cap (11.1, 11.2) in the calliper (1).
14. Push the calliper (1) against the brake carrier (2).
15. Insert new cap closures (11.1 and 11.2) into the holes in the calliper (1).
Use the long closure cap (11.2) for the long guide pin (fitting pin) (3) and the short closure cap (11.1) for the short guide pin (clearance pin) (4).



16. Carefully knock in the closure caps (11.1, 11.2) up to the end stop using a **rubber hammer** and  **WABCO tool H**.
17. Check the connecting surfaces on the fastening flange of the axle and on the brake carrier (2).
18. Remove any dirt, rust or oil.
19. Place the **new** brake with brake carrier (2) over the brake disc.
20. Install the brake on the axle in accordance with the instructions of the axle or vehicle manufacturer.
21. Tighten the bolts using a  **socket wrench, size 24 (outside)**.
22. Install the pressure plate (7), brake linings (23, 24) and wear indicator (16) ▶ Chapter "8.6 Installing the pressure plate", page 28 and ▶ Chapter "8.7 Installing the brake linings", page 29.
23. Plug the connector of the wear indicator (16) into the socket on the vehicle or the axle socket.
24. Fasten the cable to the cable clip (17) of the calliper (1).
25. Check that the cable is correctly routed.
26. Fix the cables into position using cable ties.
27. Mount the connector of the wear indicator (16) on the connector retaining plate (19).
28. Adjust the clearance ▶ Chapter "8.8 Adjusting the clearance", page 29.

Replacing the seals

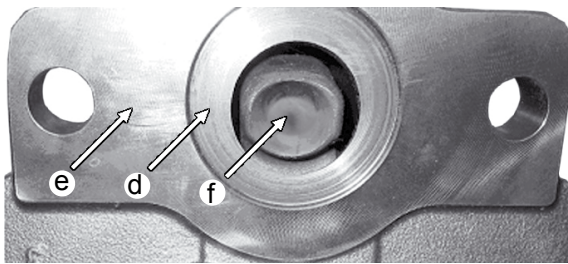

29. Clean the sealing surface (d) and flange area (e) on the calliper (1).
30. Grease the spherical cap in the brake lever (f).

WARNING

Risk of accident due to defective brake cylinder

A defective brake cylinder can cause a braking system failure and must never be installed.

- *Replace the brake cylinder if you notice any damage.*

31. Check the brake cylinder for damage, particularly at the inner area of the piston rod seal.
32. Replace the brake cylinder if you notice any damage ▶ Chapter "9 Replacing the brake cylinder", page 33.
33. Clean the sealing surface and the flange area of the brake cylinder.
34. Install the brake cylinder on the calliper (1) in accordance with the instructions of the brake cylinder manufacturer ▶ Chapter "9.2 Installing the brake cylinder", page 34.
 - ⇒ Depending on the installation position of the brake, make sure that the lower drainage aperture of the brake cylinder facing the ground is open.
 - ⇒ Depending on the brake cylinder type, the other drainage openings can either remain open or they must be sealed with a plug.
35. Check that the wheel hub moves freely.
36. Continue with ▶ Chapter "12 Final activities", page 54.

11.3 Replacing the plunger cap



If the plunger cap is removed on its own, it is not necessary to dismantle the calliper and brake cylinder.

11.3.1 Removing the plunger cap

1. Remove the brake linings (23, 24) and the pressure plate (7) ▶ Chapter "8.3 Removing the brake linings", page 25.
2. Push the calliper (1) completely to the cylinder side by hand.

Replacing the seals

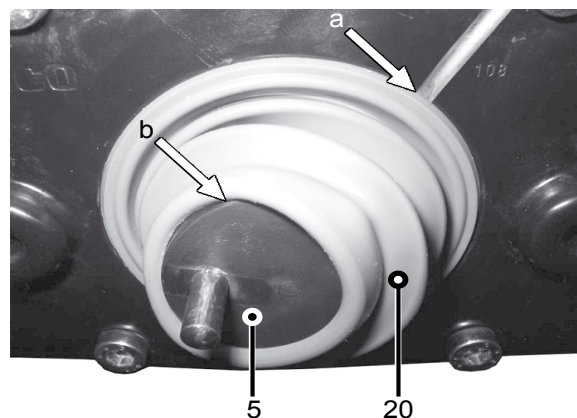
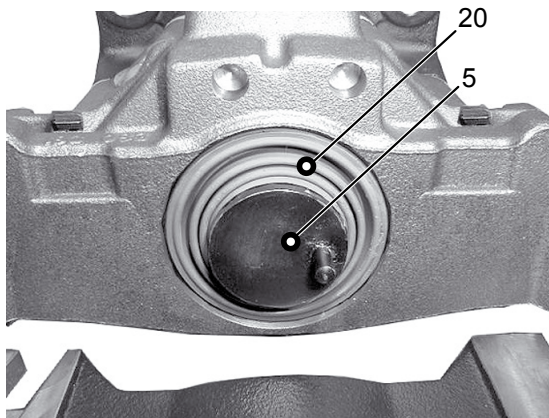

3. Pull the plunger cap (20) out of the seal seat / ring groove (arrow b) of the adjusting screw (5).

WARNING

Risk of accident from damaged brakes

Improper use of the screwdriver can damage the seal seat of the plunger cap.

Dirt or moisture can penetrate into the brake and damage it. This can cause the brake system to fail.

- *Position the screwdriver between the plunger cap and the calliper.*

4. Remove the plunger cap (20) from the seal seat of the calliper (1) with a screwdriver.
5. To do this, place the screwdriver between the plunger cap (20) and the calliper (1) (arrow a).
6. Check the calliper (1) for wear and damage.
7. Replace the brake ▶ Chapter "10 Replacing the brake", page 36 if any dirt or moisture has infiltrated the brake or if the seal seat in the calliper (1) is damaged.
8. Mark the position of the pin on the adjusting screw (5) on the calliper (1).
 - ⇒ The pin must be located in the same position after checking the adjusting screw (5).

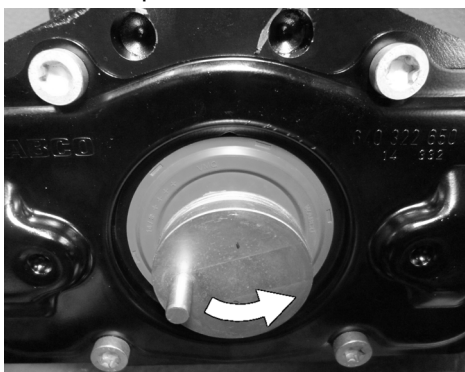

9. Turn the adjusting screw (5) by hand anti-clockwise until it protrudes about 30 mm out of the calliper (1).
10. While doing so, check the thread of the adjusting screw (5) for corrosion and damage.
11. Replace the brake ▶ Chapter "10 Replacing the brake", page 36 if the thread and/or visible interior brake parts are damaged or corroded.
12. Replace the plunger cap (20) if no dirt or water has penetrated into the calliper (1) through the seal seat or if the plunger cap (20) has been damaged during the servicing work.

Replacing the seals

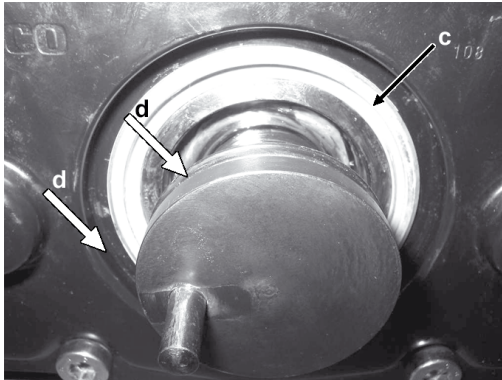

13. Make sure that the seal (arrow c) is lying correctly in the seal seat of the calliper (1).

14. If necessary, press the seal (arrow c) by hand back into the seal seat.

⚠ WARNING

Risk of accident from damaged brakes

Dirt or moisture can penetrate into the brake and damage it. This can cause the brake system to fail.

- *Make sure that no dirt or moisture penetrates into the brake when cleaning the brake cylinder.*

15. Clean the seal seats (arrow d) of the plunger cap (20) in the calliper (1) and the ring groove of the adjusting screw (5).

Make sure that the seal seat for the plunger cap (20) in the calliper (1) is clean and free of grease.

16. Grease the thread of the adjusting screw (5).

17. Turn the adjusting screw (5) clockwise back into the calliper (1) again.

- ⇒ The pin of the adjusting screw (5) must be in the same position as it was before it was unscrewed.

11.3.2 Installing the plunger cap

🔧 For this chapter, you require the following tools:

- *Open-ended spanner, size 24*
- *WABCO tool set 300 100 010 2*



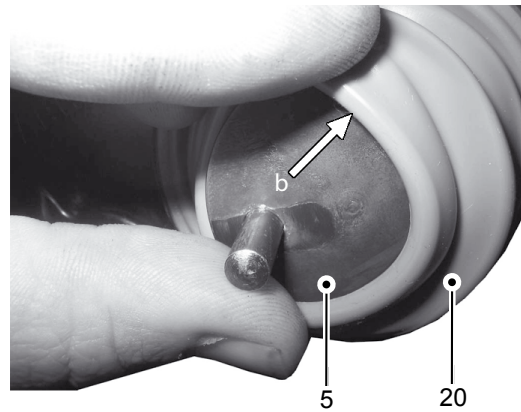
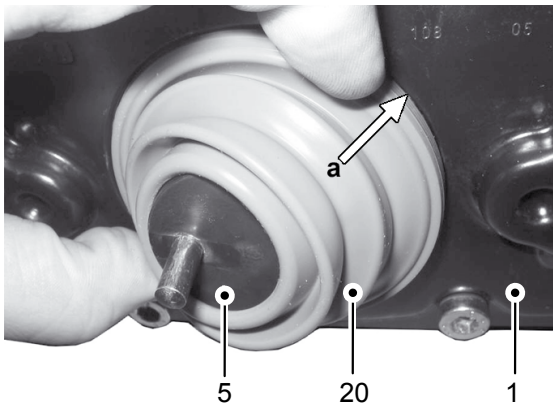

1. Grease the inner beaded edge (▶ white arrow) of the **new** plunger cap (20).

Replacing the seals

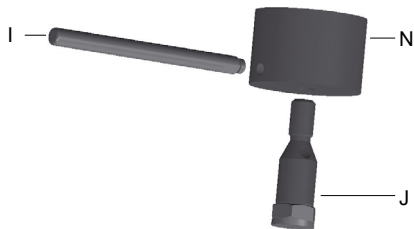

2. Slide the **new** plunger cap (20) over the adjusting screw (5).
3. Centre the plunger cap (20) and press it by hand against the seal seat (a) of the calliper (1).
4. Place the beaded edge (b) of the plunger cap (20) in the seal seat of the adjusting screw (5).







5. Use the  **WABCO tools I, J and N** for the next steps. **Tool I** is used for holding the calliper.



6. Turn the adjusting screw (5) clockwise towards the calliper (1) so that the  **WABCO tool N** can be placed on the plunger cap (20).

Replacing the seals



7. Centre the  **WABCO tool N** on the plunger cap (20).
8. Turn the  **WABCO tool J** by hand until it rests against the calliper (1) on the opposite side.
9. To press in the plunger cap (20), turn the  **WABCO tool J** using an  **open-ended spanner, size 24**, out until the plunger cap (20) is flush with the seal seat of the calliper (1).
Make sure that the cap is lying properly in the seal seat of the calliper (1), and that the beaded edge of the plunger cap (20) is lying evenly and without creasing in the ring groove of the adjusting screw (5).
10. Install the pressure plate (7) ▶ Chapter "8.6 Installing the pressure plate", page 28 and brake linings (23, 24) ▶ Chapter "8.7 Installing the brake linings", page 29.
11. Adjust the clearance ▶ Chapter "8.8 Adjusting the clearance", page 29.
12. Continue with ▶ Chapter "12 Final activities", page 54.

Replacing the seals

11.4 Replacing the return unit seal



If the seal is removed on its own, it is not necessary to dismantle the calliper (1) and brake cylinder.

11.4.1 Removing the return unit seal



For this chapter, you require the following tools:

- Screwdriver

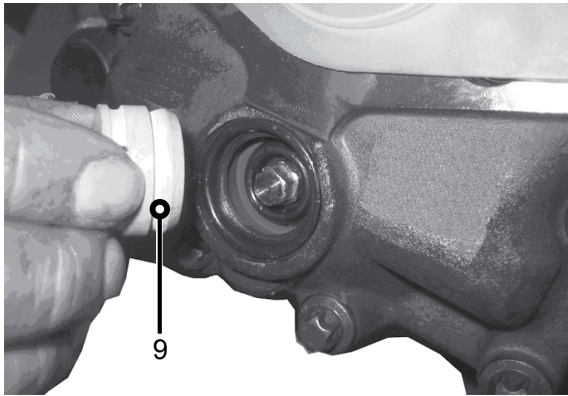

1. Remove the sealing plug of the of the return unit (9).

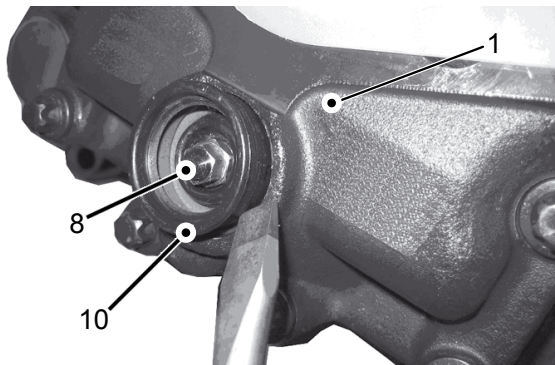

2. Use a suitable tool (e.g. screwdriver) to press the return unit seal (10) out of the calliper seat (1).
3. Remove the seal (10) from the hexagon nut on the return unit (8).

WARNING

Risk of accident from damaged brakes

Dirt or moisture can penetrate into the brake and damage it. This can cause the brake system to fail.

- *Make sure that no dirt or moisture penetrates into the brake when cleaning the brake cylinder.*

Replacing the seals

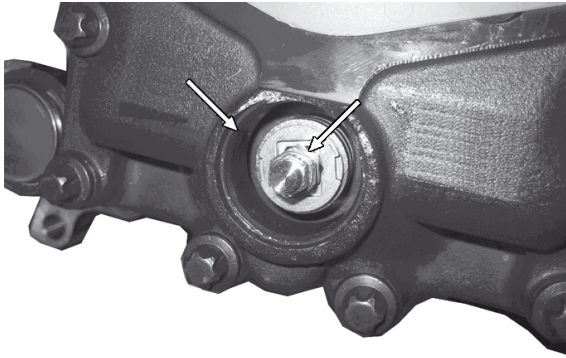

4. Clean the seal seats (▶ white arrows) of the seal of the return unit (10) in the calliper (1).
5. Use a suitable tool (e.g. screwdriver) to press the return unit seal (10) out of the calliper seat (1).
6. Remove the seal (10) from the hexagon nut on the return unit (8).
7. Check the calliper (1).
8. Replace the brake ▶ Chapter "10 Replacing the brake", page 36 if it has been penetrated by dirt or moisture.
9. If the seal seat in the calliper (1) or the hexagon nut on the return unit (8) is damaged, replace the brake ▶ Chapter "10 Replacing the brake", page 36.

11.4.2 Installing the return unit seal



A mounting cap and mounting sleeve are included with the repair kit for the return unit seal.

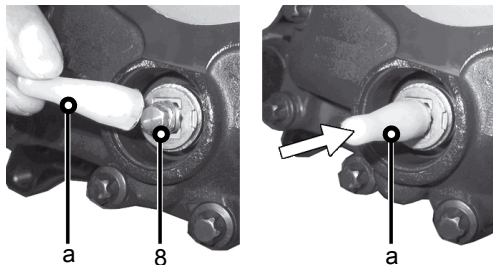

1. Place the mounting cap (a) on the return unit hexagon screw (8).
2. Push on the mounting cap (a) up to the end stop.

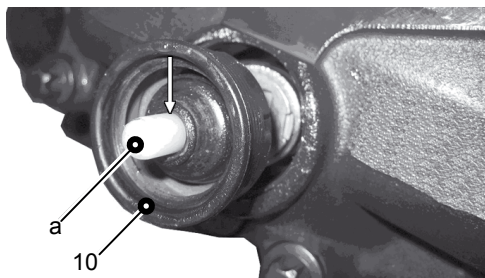

3. Lightly grease a **new** return unit seal (10) at the inner sealing bead (▶ white arrow).
4. Place the return unit seal (10) on the mounting cap (a).
5. Press the return unit seal (10) by hand into the calliper seat (1) up to the stop.

Replacing the seals

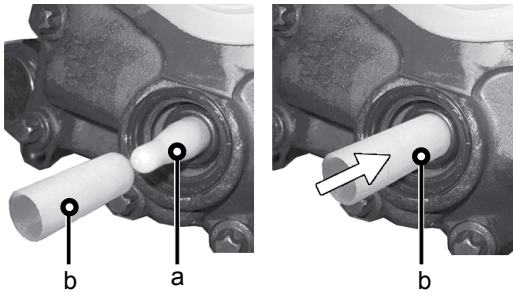

6. Place the mounting sleeve (b) on the mounting cap (a).
7. Press the mounting sleeve (b) against the inner sealing bead of the return unit seal (10) until the sealing bead is lying in the ring groove in the return unit.

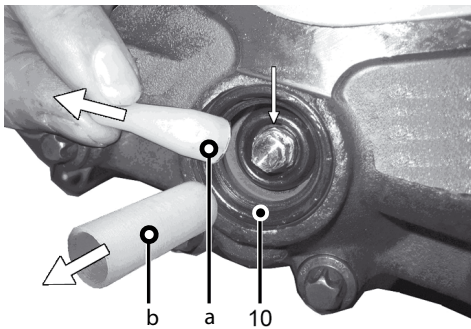

8. Remove the mounting sleeve (b) and mounting cap (a).
9. Make sure that the return unit seal (10) is fully inserted in the seal seat of the calliper (1) and in the ring groove (▶ small white arrow) in the return unit.

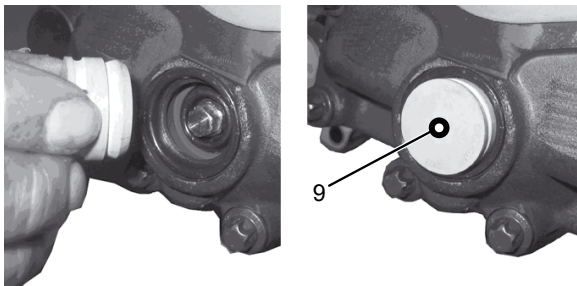

10. Push a **new** sealing plug (9) into the return unit seal (10).
Make sure that the sealing plug (9) is fitted tightly.

12 Final activities

After successful installation of the disc brake, proceed as follows:

- Make sure that the loosening screw of the spring chamber cylinder is fully screwed in.
- Mount the vehicle wheel in accordance with the instructions of the axle or vehicle manufacturer.
- Check the functionality of the parking brake.
- Perform a concluding test on the roller test stand.
- If no roller test stand is available, conduct a test drive with brake action tests.
- Inform the driver that full braking (with the exception of emergency braking) must not be performed for the first 50 kilometres after new brake linings have been fitted.
- Inform the driver that he should avoid prolonged braking to prevent heat cracks and warping of the brake.

13 Spare parts

- Identify the brake from the WABCO part number.

WABCO type plate

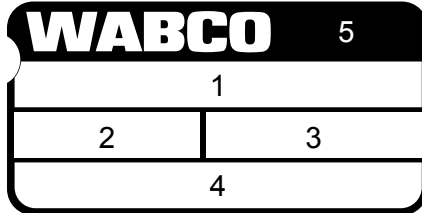

Legend	
1	Customer number
2	Production date
3	Serial number
4	Assembly number
5	Country of manufacture



Spare parts can be found on the following web page by entering the WABCO brake part number: <http://inform.wabco-auto.com/>

14 Disposal

- The final and professional decommissioning and disposal of the product must be carried out in accordance with the applicable legal regulations of the user country. In particular, the regulations for the disposal of batteries, equipment and the electrical system must be observed.
- Electrical appliances must be collected separately from household or commercial waste and recycled or disposed of in accordance with regulations.
- If applicable, take the old device to the company's internal disposal department, which will then forward it to specialist companies (specialist disposal companies).
- In principle, it is also possible to return the old device to the manufacturer. For this purpose, contact the manufacturer's customer service. Any special agreements must be observed.
- Electrical and electronic equipment must be collected separately from unsorted municipal waste and recycled or disposed of properly, because harmful substances can cause lasting damage to health and the environment if disposed of improperly.
- Detailed information can be obtained from specialist waste management companies or the responsible authorities.
- The packaging must be disposed of separately. Paper, cardboard and plastics must be recycled.

15 WABCO regional offices

 WABCO Headquarters, Giacomettistrasse 1, 3006 Bern 31, Switzerland, Tel: +32-2663 98 00		
 WABCO Europe BVBA Chaussée de la Hulpe 166 1170 Brüssel Belgium T: +32 2 663 9800 F: +32 2 663 9896	 WABCO Belgium BVBA/SPRL 't Hofveld 6 B1-3 1702 Groot-Bijgaarden Belgium T: +32 2 481 09 00	 WABCO Austria GesmbH Rappachgasse 42 1110 Vienna Austria T: +43 1 680 700
 WABCO GmbH Am Lindener Hafen 21 30453 Hannover Germany T: +49 511 9220	 WABCO GmbH Gartenstraße 1 31028 Gronau Germany T: +49 511 922 3000	 WABCO Radbremsen GmbH Bärlochweg 25 68229 Mannheim Germany T: +49 621 48310
 WABCO brzdy k vozidlům spol. s r.o. Sourcing & Purchasing Office U Trezorky 921/2 Prague 5 Jinonice 158 00 Prague Czech Republic T: +420 226 207 010	 WABCO brzdy k vozidlům spol. s r.o. Pražákova 1008/69, Štýřice, 639 00 Brno Czech Republic T: +420 543 428 800	 WABCO Automotive BV Rhijnspoor 263 Capelle aan den IJssel (Rotterdam) 2901 LB Netherlands T: +31 10 288 86 00
 WABCO (Schweiz) GmbH Morgenstrasse 136 Bern 3018 Switzerland T: +41 31 997 41 41	 WABCO International Sourcing & Purchasing Office Harmandere Mh. Dedepasa Cd. 24 Atlas Park B/5 Pendik, 34912 Istanbul Turkey T: +90 216 688 81 72 Fax: +90 216 688 38 26	 WABCO Sales Office Halide Edip Adivar Mh. Ciftecevizler Deresi Sok. 2/2 Akin Plaza, Sisli, 34382 Istanbul Turkey T: +90 212 314 20 00 Fax: +90 212 314 20 01
 WABCO France Carre Hausmann 1 cours de la Gondoire 77600 Jossigny France T: +33 801 802 227	 WABCO Automotive Italia S.r.L. Studio Tributario e Societario, Galleria San Federico 54 Torino, 10121 Italy T: +39 011 4010 411	 WABCO Polska Spółka Z Ograniczona Odpowiedzialnoscia ul. Ostrowskiego 34 53-238 Wroclaw Poland T: +48 71 78 21 888
 WABCO España S. L. U. Av de Castilla 33 San Fernando de Henares Madrid 28830 Spain T: +34 91 675 11 00	 WABCO Automotive AB Drakegatan 10, Box 188 SE 401 23 Gothenburg Sweden T: +46 31 57 88 00	 WABCO Automotive U.K. Ltd Unit A1 Grange Valley Grange Valley Road, Batley, W Yorkshire, England, WF17 6GH T: +44 (0)1924 595 400

WABCO regional offices

 <p>WABCO Australia Pty Ltd Unit 3, 8 Anzed Court Mulgrave, Victoria 3170 Australia T: +61 3 8541 7000 Hotline: 1300-4-WABCO</p>	 <p>WABCO do Brasil Indústria e Comércio De Freios Ltda Rodovia Anhanguera, km 106 CEP 13180-901 Sumaré-SP Brazil T: +55 19 2117 4600 T: +55 19 2117 5800</p>	 <p>WABCO Hong Kong Limited 14/F Lee Fund Centre 31 Wong Chuk Hang Road Hong Kong China T: +852 2594 9746</p>
 <p>Asia Pacific Headquarters, WABCO (Shanghai) Mgmt Co. Ltd 29F & 30F, Building B, New Caohejing Intl Bus. Center 391 Guiping Rd, Xuhui Dist. Shanghai 200233, China T: +86 21 3338 2000</p>	 <p>WABCO (China) Co. Ltd. Jinan Shandong WABCO Automotive Products Co. Ltd. 1001 Shiji Av, Jinan Indust. Zone, Shandong 250104 China T: +86 531 6232 8800</p>	 <p>WABCO (China) Co. Ltd No. 917 Weihe Road, Economic & Tech. Dev. Zone Qingdao 266510 China T: +86 532 8686 1000</p>
 <p>WABCO (China) Co. Ltd Guangdong WABCO FUHUA Automobile Brake System Co. Ltd. Building E, No. 1 North, Santai Av, Taishan City Guangdong 529200 China T: +86 750 5966 123</p>	 <p>Shanghai G7 WABCO IOT Technology Co. Ltd Room 503, Ligu Building, No. 255 Wubao Road, Minhang Dist. Shanghai 201100 China T: 021-64058562/826</p>	 <p>China-US RH Sheppard Hubei Steering Systems Co. Ltd No. 18, Jingui Road, Xianning City Hubei 437000 China</p>
 <p>WABCO India Limited Plot No. 3 (SP), III Main Road Ambattur Industrial Estate Chennai 600 058 India T: +91 44 42242000</p>	 <p>WABCO Japan Inc Gate City Ohsaki W. Tower 2F, 1-11-1, Osaki, Shinagawa-ku, Tokyo 141-0032 Japan T: +81 3 5435 5711</p>	 <p>WABCO Korea Ltd 23, Cheongbuksandan-ro, Cheongbuk-eup Pyongtaek-si Gyeonggi-do, 17792 Korea T: +82 31 680 3707</p>
 <p>WABCO Asia Private Ltd 25 International Business Park #03-68/69 German Centre 609916 Singapore T: +65 6562 9119</p>	 <p>WABCO Automotive SA 10 Sunrock Close Sunnyrock Ext 2, Germison 1401 PO Box 4590, Edenvale 1610 South Africa T: +27 11 450 2052</p>	 <p>WABCO Middle East and Africa FZCO Vehicle Control System DWC Business Park, Building A3, Room NO: 115, PO Box 61231, Dubai United Arab Emirates E-mail: info.dubai@wabco-auto.com</p>

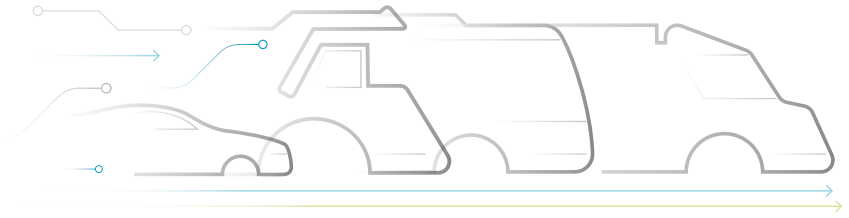

ACE

AUTONOMOUS
CONNECTED
ELECTRIC

About WABCO

WABCO (NYSE: WBC) is the world's leading supplier of brake control systems and other advanced technologies to improve the safety, efficiency and connectivity of commercial vehicles. Founded about 150 years ago as Westinghouse Air Brake Company, WABCO is committed to an increasingly autonomous, networked and electrical future for the commercial vehicle industry, true to the motto "Mobilizing Vehicle Intelligence". WABCO continuously drives the development of forward-looking innovations with the aim of setting important technological milestones in the field of autonomous mobility and uses its

extensive expertise to integrate complex control and fail-safe systems required for efficient and safe control of vehicle dynamics in every phase of vehicle operation - on the motorway, in the city and in the depot. The world's leading manufacturers of trucks, buses and trailers rely on WABCO's cutting edge technologies. Powered by its vision for accident-free driving and greener transportation solutions, WABCO is also at the forefront of advanced fleet management systems that contribute to commercial fleet efficiency. In 2018, WABCO reported sales of \$3.8 billion and has nearly 16,000 employees more than 40 countries. For more information, visit www.wabco-auto.com

WABCO

Mobilizing Vehicle Intelligence